



## 05157800 - LT-A D55 ER20F L-R H125RF1:2MU

<b>Tipo</b>	LT-A Portautensili angolare a 90°
<b>Attacco</b>	GAMBO CILINDRICO 55
<b>Uscita utensile</b>	Portapinza ER 20 F - ghiera interna
<b>Raffreddamento</b>	Refrigerazione interna
<b>Senso di rotazione</b>	r1  r2 
<b>Velocità max [1/min]</b>	in 5000 / out 10000
<b>Coppia max [Nm]</b>	in 50 / out 25
<b>Rapporto</b>	1:2
<b>H [mm]</b>	125
<b>H1 [mm]</b>	27
<b>Accessori</b>	N.D.
<b>Note</b>	N.D.
<b>Note per il montaggio</b>	Può avere delle limitazioni per alcune installazioni



Verificare sempre gli ingombri del portautensile in torretta

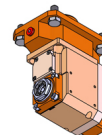
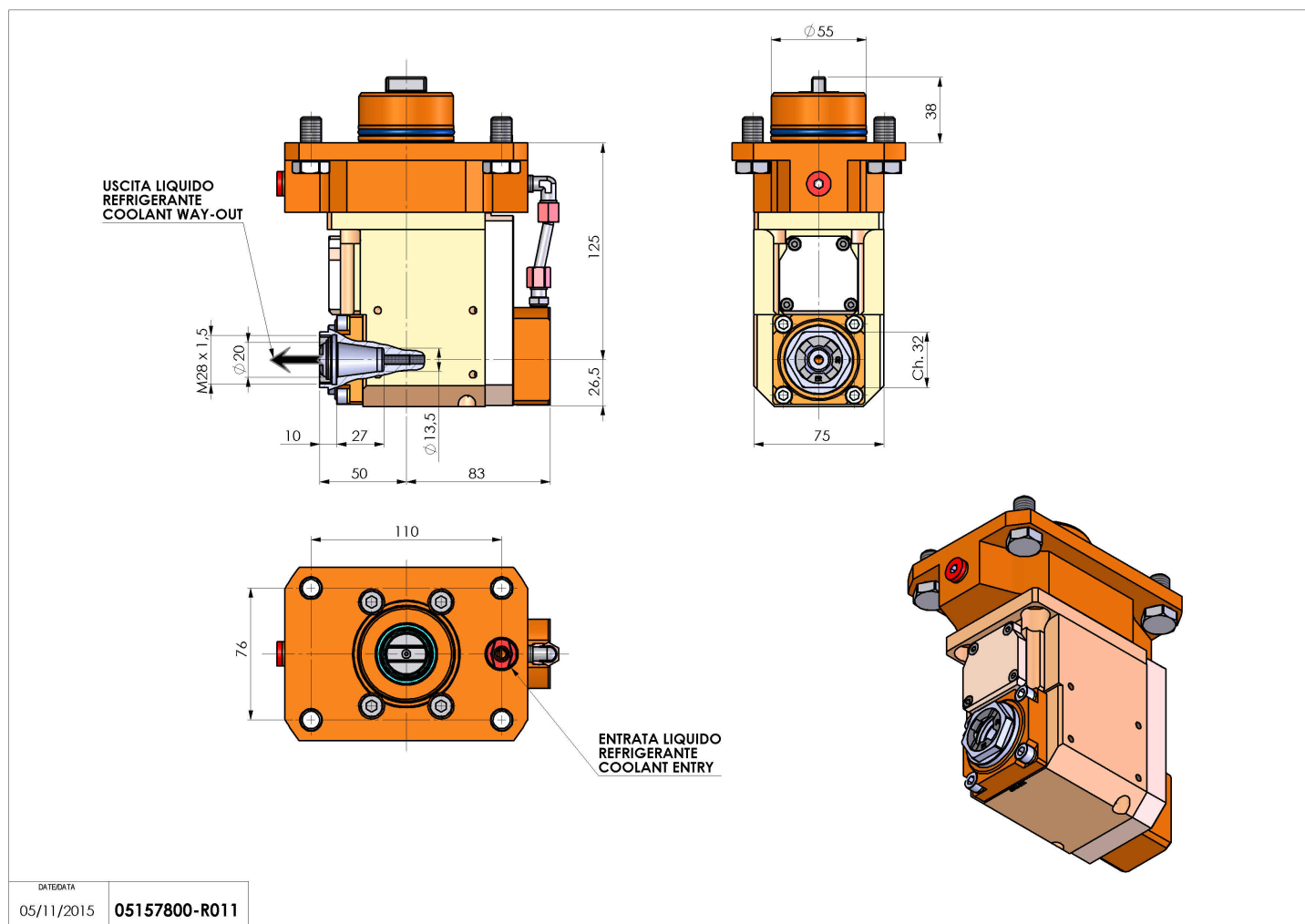

Salvo modifiche tecniche

DATE/DATE  
05/11/2015 05157800-R011