



05364100 - LT-S D55.4 ER32F OFS63.5 LR HRF 2:1 H86.5

| | |
|------------------------------|---|
| Tipo | LT-S OFS Portautensili dritto offset |
| Attacco | GAMBO CILINDRICO 55,4 |
| Uscita utensile | Portapinza ER 32 F - ghiera interna |
| Raffreddamento | Refrigerazione interna HP |
| Offset [mm] | 63.5 |
| Senso di rotazione | r1  r2  |
| Velocità max [1/min] | in 6000 / out 3000 |
| Coppia max [Nm] | in 25 / out 50 |
| Rapporto | 2:1 |
| H [mm] | 86.5 |
| Accessori | N.D. |
| Note | N.D. |
| Note per il montaggio | Può avere delle limitazioni per alcune installazioni |



Verificare sempre gli ingombri del portautensile in torretta

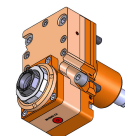
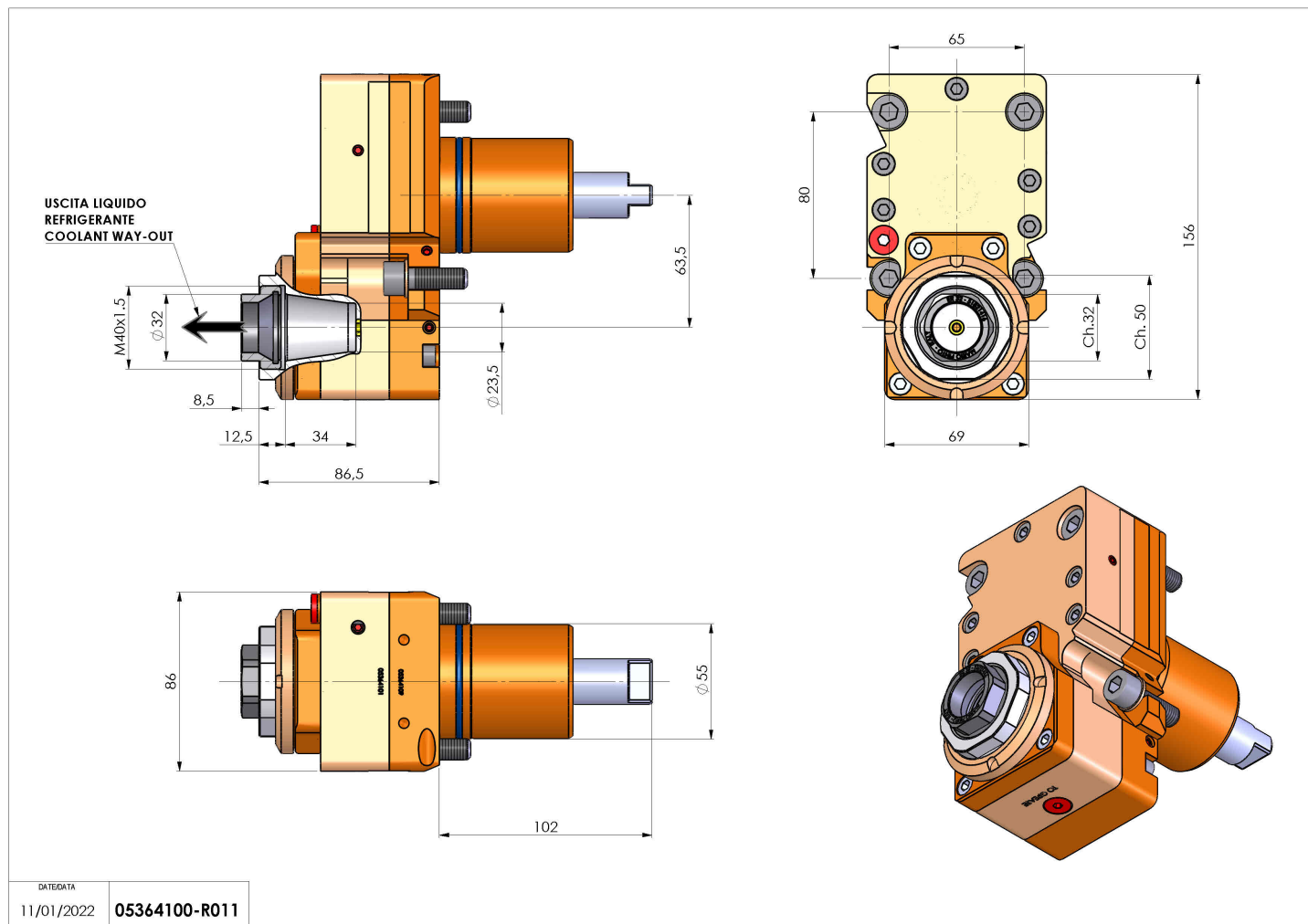

Salvo modifiche tecniche