



05331800 - LT-S BMT65 C40 H56

Tipo	LT-S Portautensili dritto
Attacco	BMT 65
Uscita utensile	Uscita poligonale C40 ISO 26623-1
Raffreddamento	Refrigerazione esterna
Senso di rotazione	r1  r2 
Velocità max [1/min]	6000
Coppia max [Nm]	70
Rapporto	1:1
H [mm]	56
Accessori	N.D.
Note	N.D.
Note per il montaggio	Può avere delle limitazioni per alcune installazioni



Verificare sempre gli ingombri del portautensile in torretta

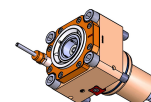
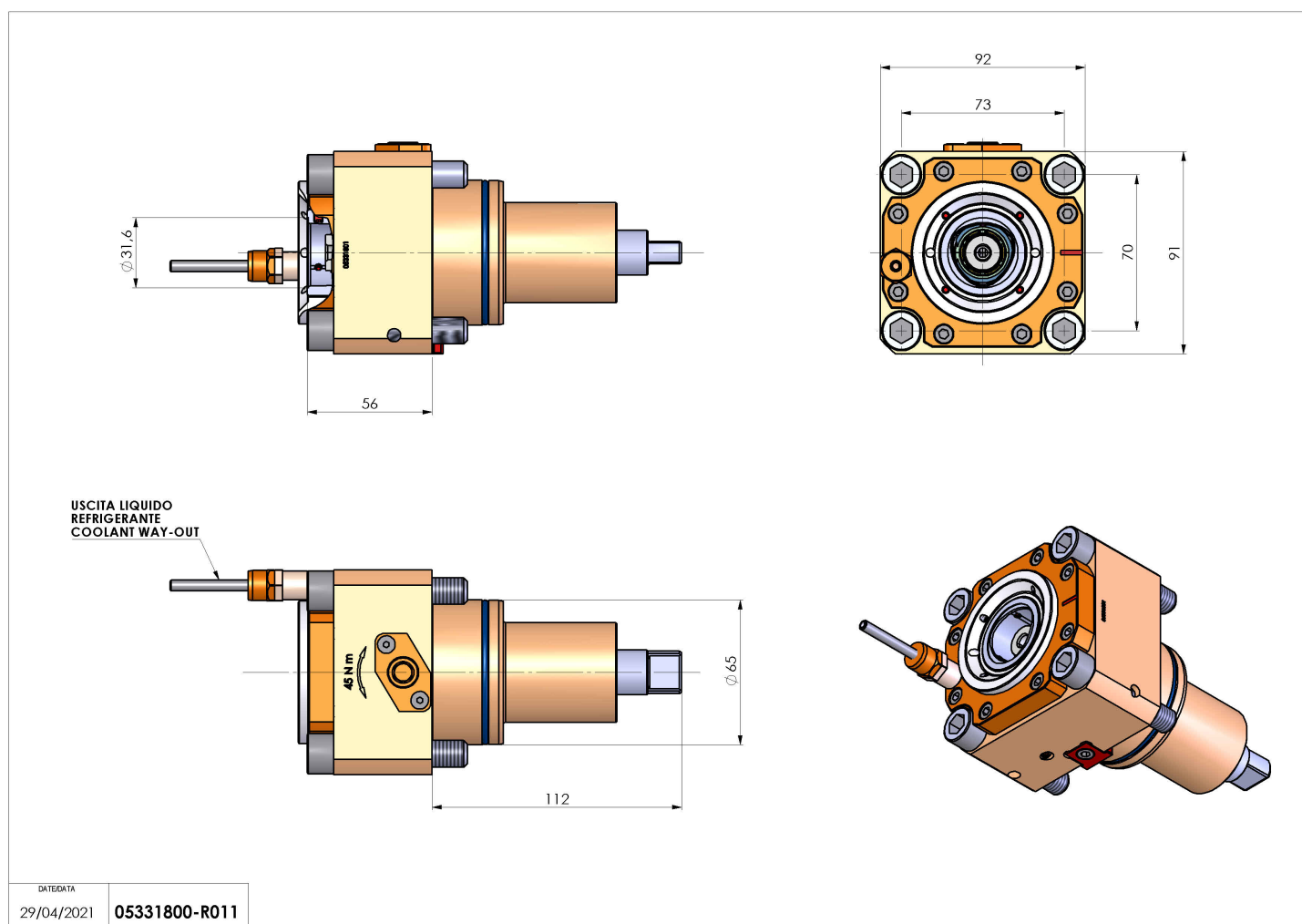

Salvo modifiche tecniche

DATE/ATA	05331800-R011
29/04/2021	