

05400800 - LT-S D60 DIN138-22 H77

Type	LT-S Tool holder straight
Mounting	CYLINDRICAL SHANK 60
Tool output	Shell-Mill DIN138 22
Coolant	External coolant
Direction of rotation	r1 ↻ r2 ↻
Max speed [rpm]	6000
Max torque [Nm]	70
Ratio	1:1
H [mm]	77
Accessories	N.A.
Notes	N.A.
Mounting tips	Not suitable for every application, please check

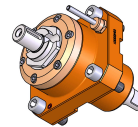

Always check live tool dimensions on the turret

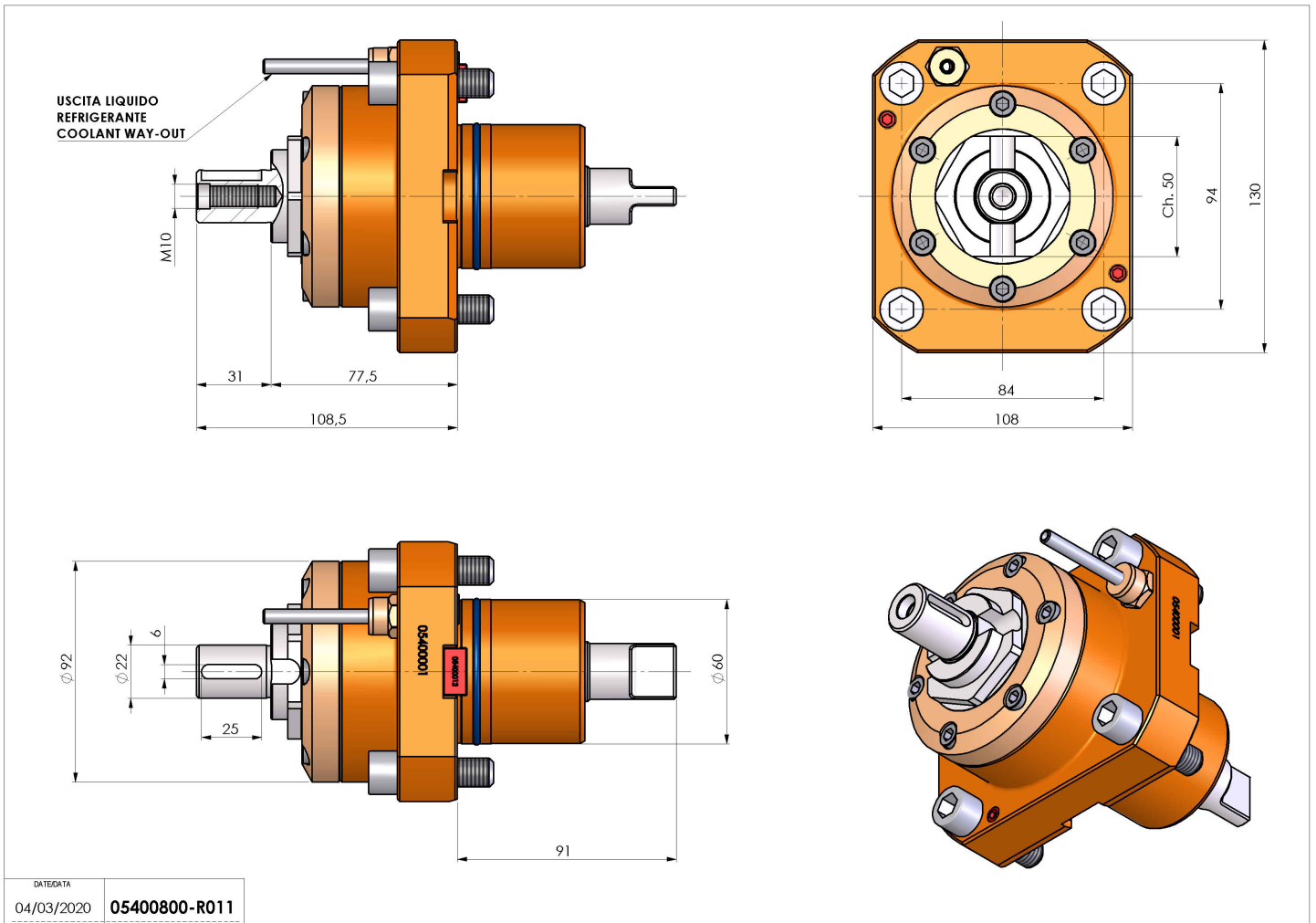

DATE/DATE 04/03/2020 05400800-R011

Subject to technical changes