

05355600 - LT-A VDI40ER20FRFH-PRH1301:2MZ

Type	LT-A Tool holder angle 90°
Mounting	VDI 40
Tool output	Collet nut ER 20 F - internal nut
Coolant	Internal coolant
Direction of rotation	r1 ↻ r2 ↻
Max speed [rpm]	in 5000 / out 10000
Max torque [Nm]	in 50 / out 25
Ratio	1:2
H [mm]	130
H1 [mm]	27
Max pressure [bar]	80
Accessories	N.A.
Notes	N.A.
Mounting tips	Not suitable for every application, please check

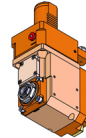

ATTENZIONE: VERIFICARE L'ORIENTAMENTO DELLA DENTATURA VDI

Always check live tool dimensions on the turret

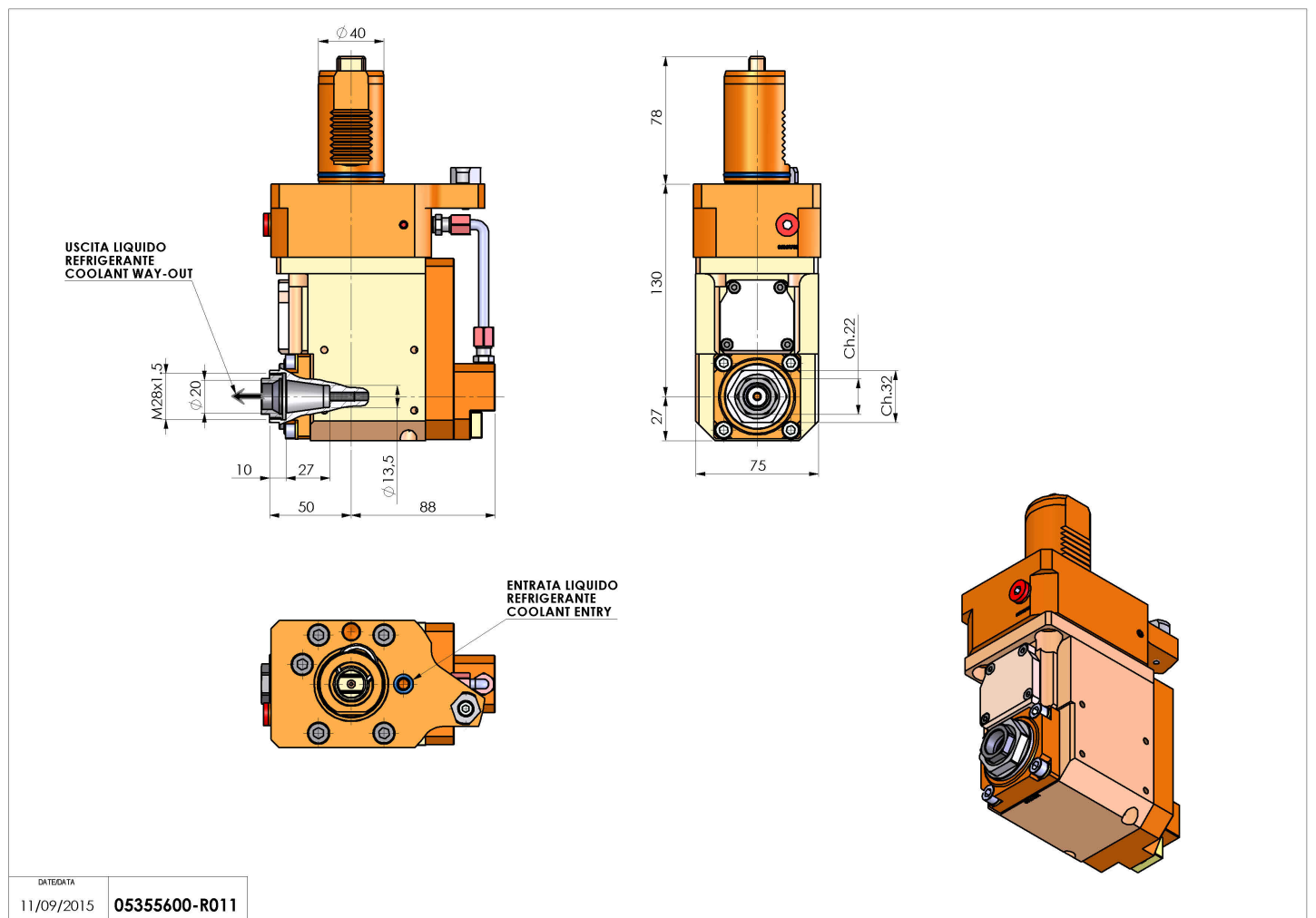

DATE/DATE	11/09/2015	05355600-R011
-----------	------------	---------------

Subject to technical changes