



05354900 - LT-S D68 ER32 HRF HS H90

Type	LT-S Tool holder straight
Mounting	CYLINDRICAL SHANK 68
Tool output	Collet nut ER 32
Coolant	HP Internal coolant
Direction of rotation	r1  r2 
Max speed [rpm]	10000
Max torque [Nm]	63
Ratio	1:1
H [mm]	90
Max pressure [bar]	70
Accessories	N.A.
Notes	N.A.
Mounting tips	Not suitable for every application, please check



Always check live tool dimensions on the turret

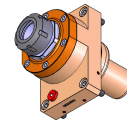
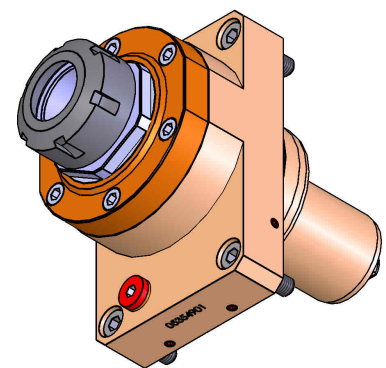
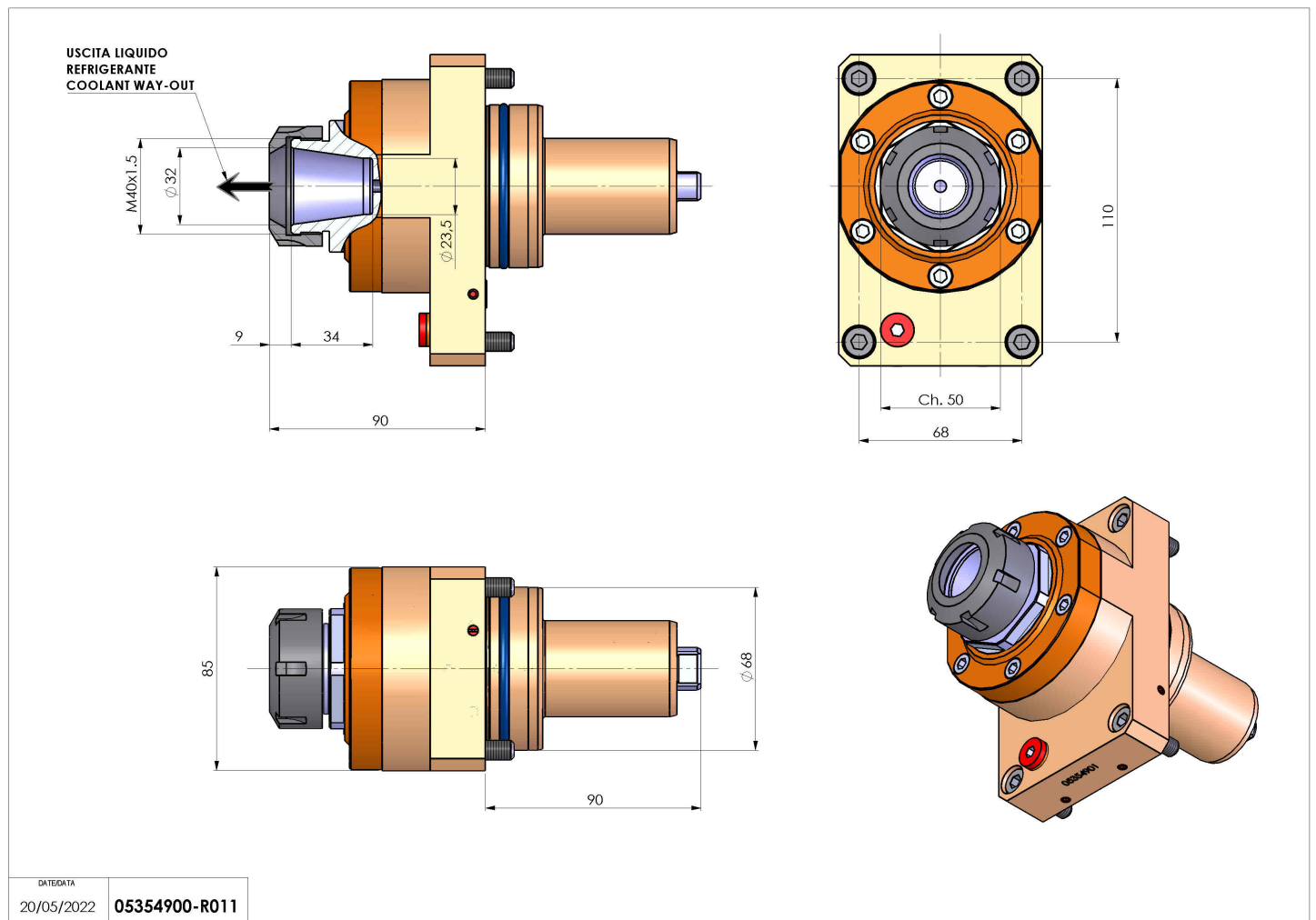

Subject to technical changes