

05350400 - LT-AOFS1:1.75D68ER25FKRH84.5MZ

Type	LT-A OFS Tool holder offset angle 90°
Mounting	CYLINDRICAL SHANK 68
Tool output	Collet nut ER 25 F - internal nut
Coolant	External coolant
Direction of rotation	r1 ↻ r2 ↻
Max speed [rpm]	in 5700 / out 10000
Max torque [Nm]	in 25 / out 14
Ratio	1:1,75
H [mm]	84,5
H1 [mm]	32,5
Accessories	N.A.
Notes	N.A.
Mounting tips	Not suitable for every application, please check

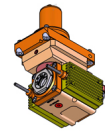

Always check live tool dimensions on the turret

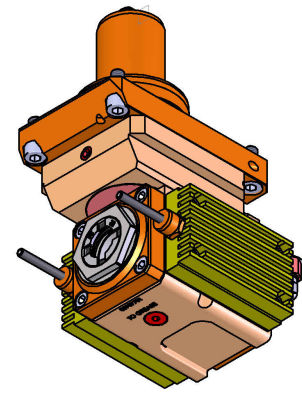
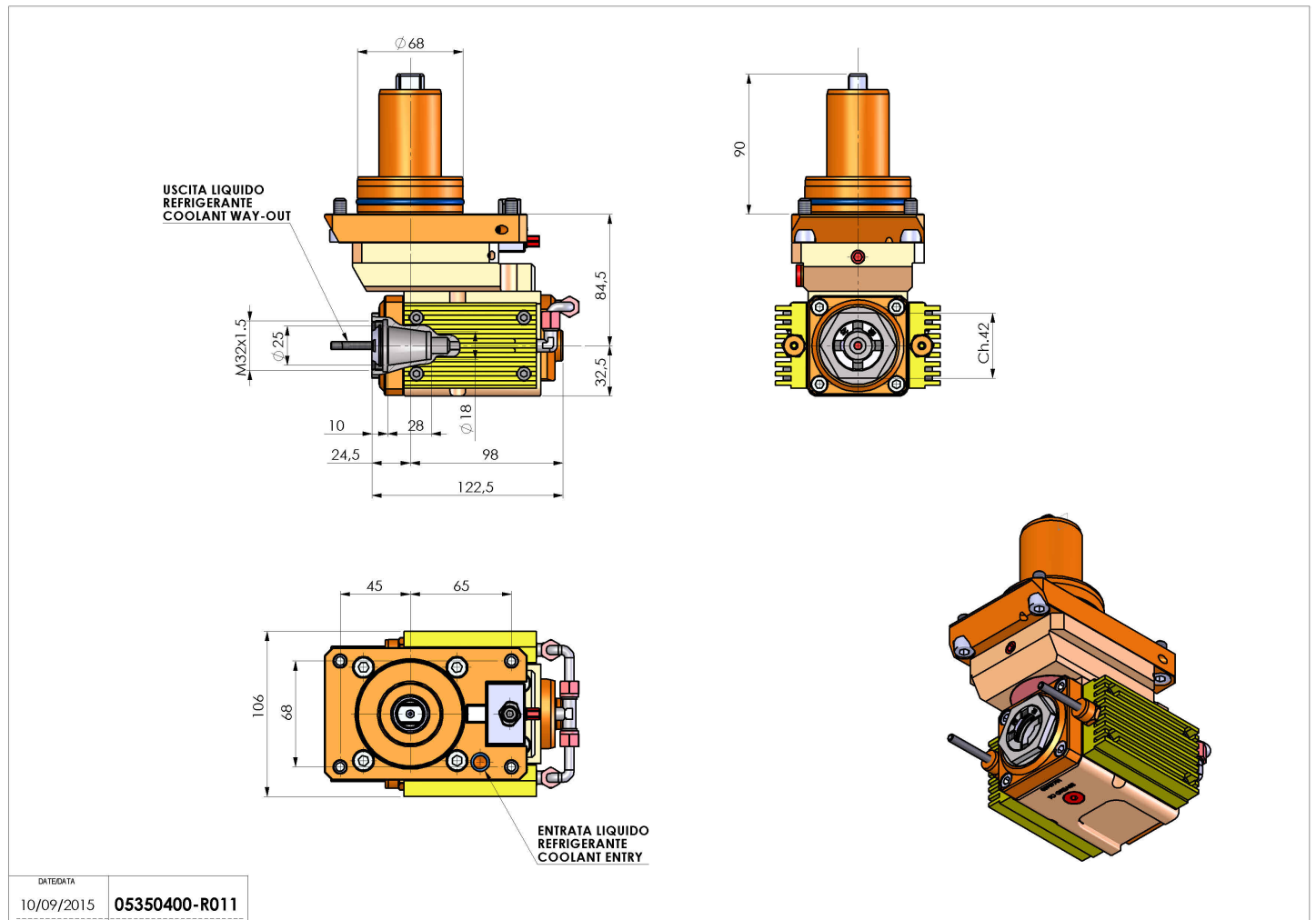

Subject to technical changes