

05313300 - LT-S BMT 65 BD ER32F H61

Type	LT-S Tool holder straight
Mounting	BMT 65 BIG DRIVE
Tool output	Collet nut ER 32 F - internal nut
Coolant	External coolant
Direction of rotation	r1 ↻ r2 ↻
Max speed [rpm]	6000
Max torque [Nm]	70
Ratio	1:1
H [mm]	60
Accessories	N.A.
Notes	N.A.
Mounting tips	Not suitable for every application, please check

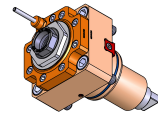

Always check live tool dimensions on the turret

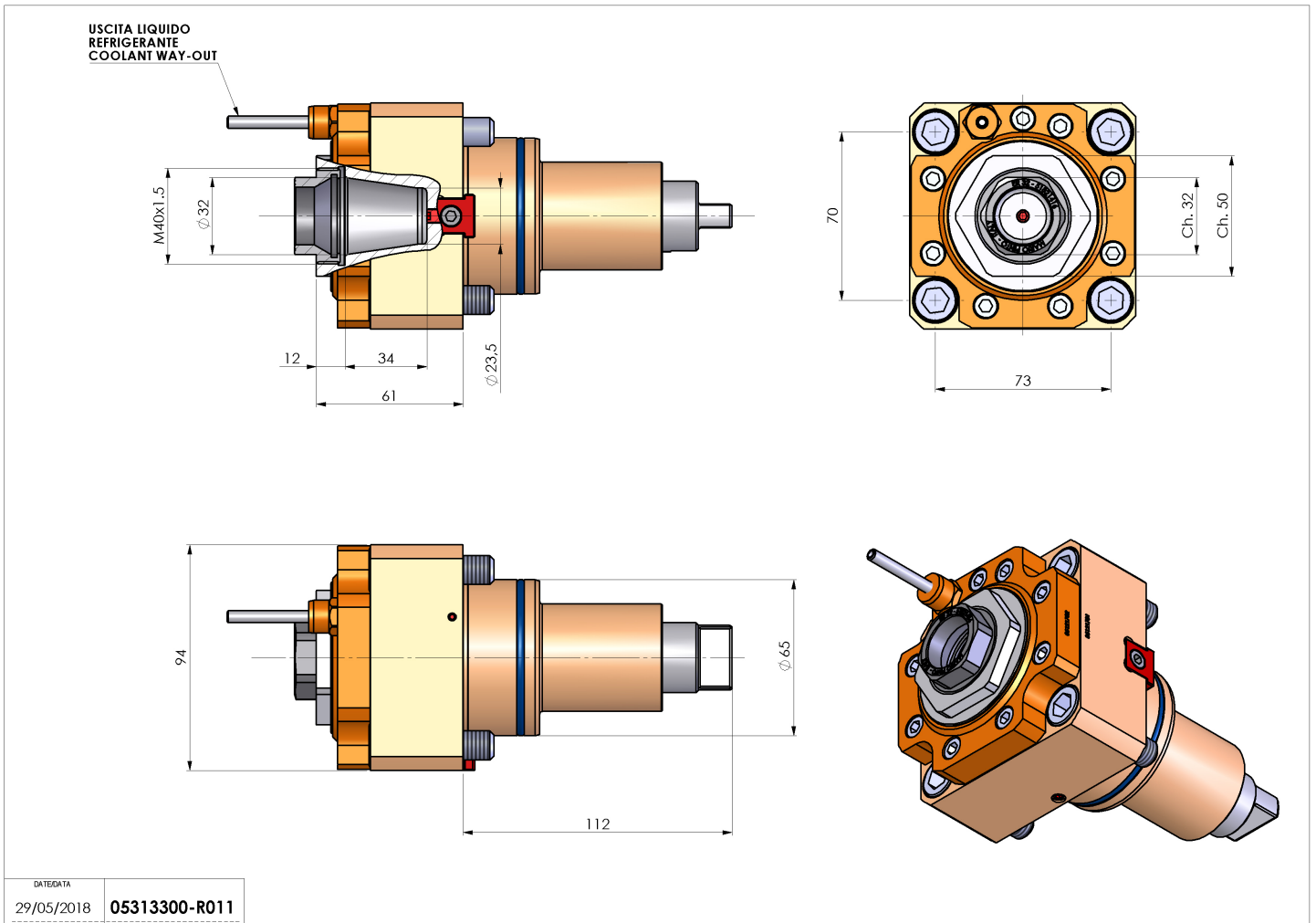

DATE/DATE	05313300-R011
29/05/2018	

Subject to technical changes