

05291500 - LT-T D32 ER16F H50-119

Type	LT-T Tool holder tiltable
Mounting	CYLINDRICAL SHANK 32
Tool output	Collet nut ER 16 F - internal nut
Coolant	External coolant
Direction of rotation	r1 r2
Max speed [rpm]	6000
Max torque [Nm]	10
Ratio	1:1
H [mm]	50-119
Accessories	N.A.
Notes	N.A.
Mounting tips	Not suitable for every application, please check

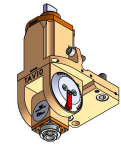

Always check live tool dimensions on the turret

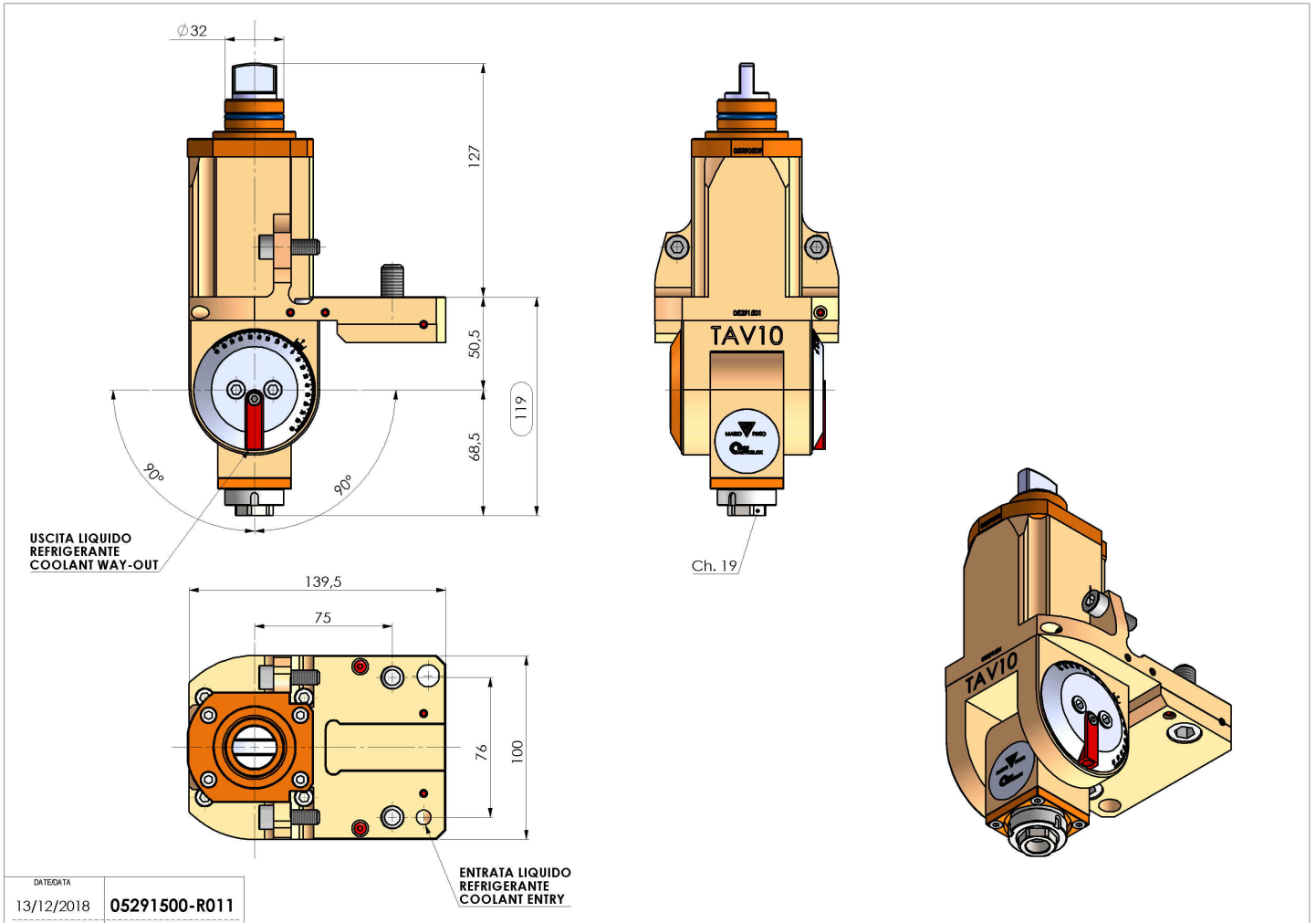

DATE/ATA
13/12/2018 05291500-R011

Subject to technical changes