

05281400 - LT-S D54 ER32 H89 MY

| | |
|------------------------------|--|
| Type | LT-S Tool holder straight |
| Mounting | CYLINDRICAL SHANK 54 |
| Tool output | Collet nut ER 32 |
| Coolant | External coolant |
| Direction of rotation | r1 r2 |
| Max speed [rpm] | 6000 |
| Max torque [Nm] | 40 |
| Ratio | 1:1 |
| H [mm] | 89 |
| Accessories | |
| Notes | N.A. |
| Mounting tips | Not suitable for every application, please check |

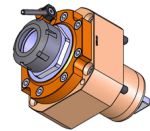

Always check live tool dimensions on the turret

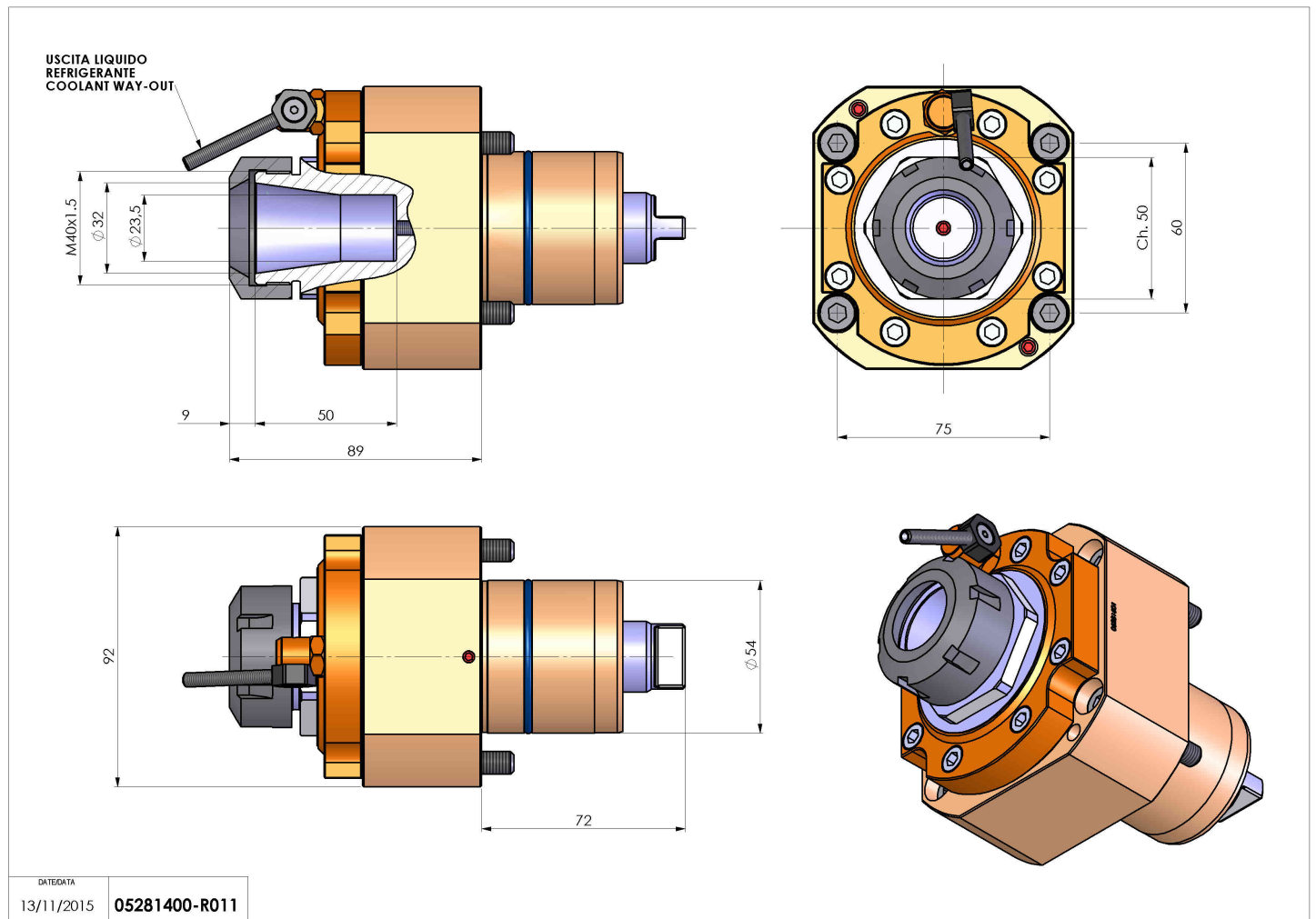

| | |
|-------------|---------------|
| DATE/DATE | 13/11/2015 |
| PART NUMBER | 05281400-R011 |

Subject to technical changes