

05262300 - LT-S D55.4 DIN138-16 H46 OK

| | |
|------------------------------|--|
| Type | LT-S Tool holder straight |
| Mounting | CYLINDRICAL SHANK 55,4 |
| Tool output | Shell-Mill DIN138 16 |
| Coolant | External coolant |
| Direction of rotation | r1 ↻ r2 ↻ |
| Max speed [rpm] | 6000 |
| Max torque [Nm] | 40 |
| Ratio | 1:1 |
| H [mm] | 46 |
| Accessories | |
| Notes | N.A. |
| Mounting tips | Not suitable for every application, please check |

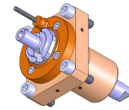

Always check live tool dimensions on the turret

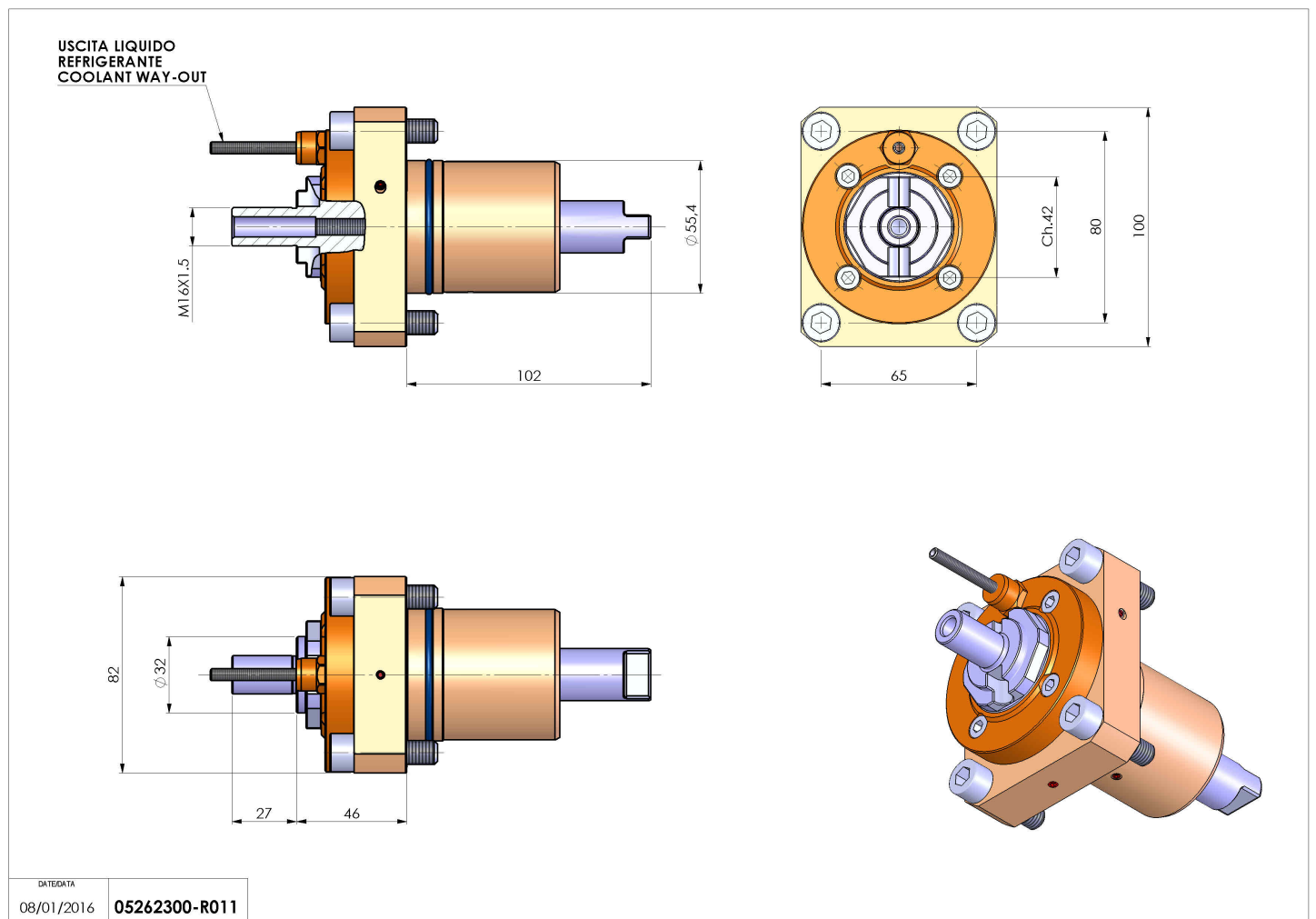

DATE/DATE
08/01/2016 05262300-R011

Subject to technical changes