

05258100 - LT-S2VDI40ER20F-20FH1231:1Q2MZ

| | |
|------------------------------|--|
| Type | LT-S2 Tool holder double straight |
| Mounting | VDI 40 |
| Tool output | Collet nut ER 20 F - internal nut |
| Coolant | External coolant |
| Direction of rotation | r1 ↻ r2 ↻ r3 ↻ |
| Max speed [rpm] | 6000 |
| Max torque [Nm] | 38 |
| Ratio | 1:1 |
| H [mm] | 123 |
| Accessories | N.A. |
| Notes | N.A. |
| Mounting tips | Not suitable for every application, please check |

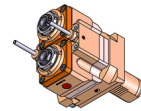

ATTENZIONE: VERIFICARE L'ORIENTAMENTO DELLA DENTATURA VDI

Always check live tool dimensions on the turret

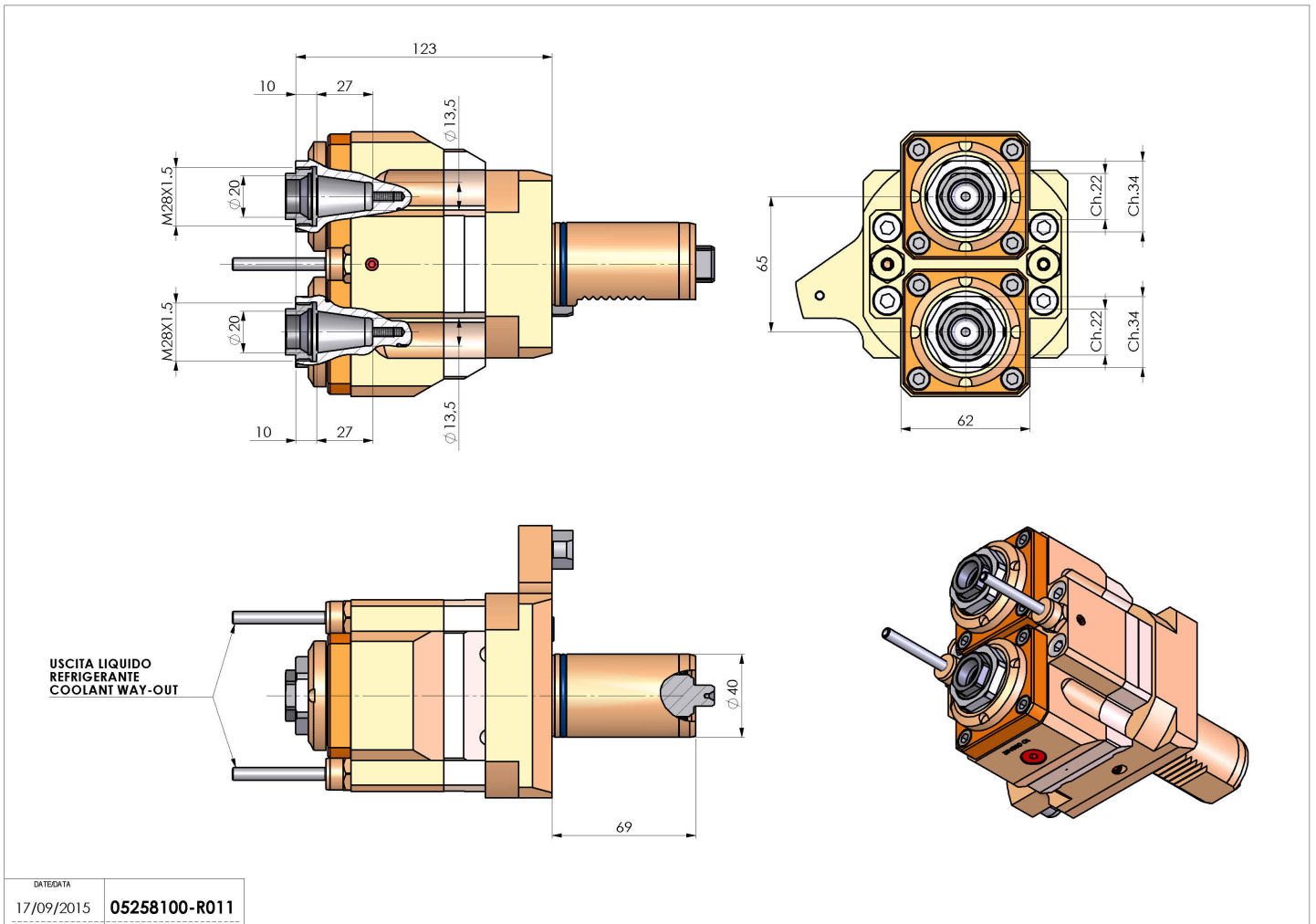

| | |
|------------|---------------|
| DATE/DATE | 05258100-R011 |
| 17/09/2015 | |

Subject to technical changes