

05250600 - LT-A VDI40 ER32F-32F L H130 MZ

Type	LT-A DBL Tool holder double angle 90°
Mounting	VDI 40
Tool output	Collet nut ER 32 F - internal nut
Coolant	External coolant
Direction of rotation	r1 ↻ r2 ↻ r3 ↻
Max speed [rpm]	6000
Max torque [Nm]	63
Ratio	1:1
H [mm]	130
H1 [mm]	37,5
Accessories	N.A.
Notes	Only for some version with Matrix CNC
Mounting tips	Not suitable for every application, please check

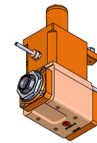

ATTENZIONE: VERIFICARE L'ORIENTAMENTO DELLA DENTATURA VDI

Always check live tool dimensions on the turret

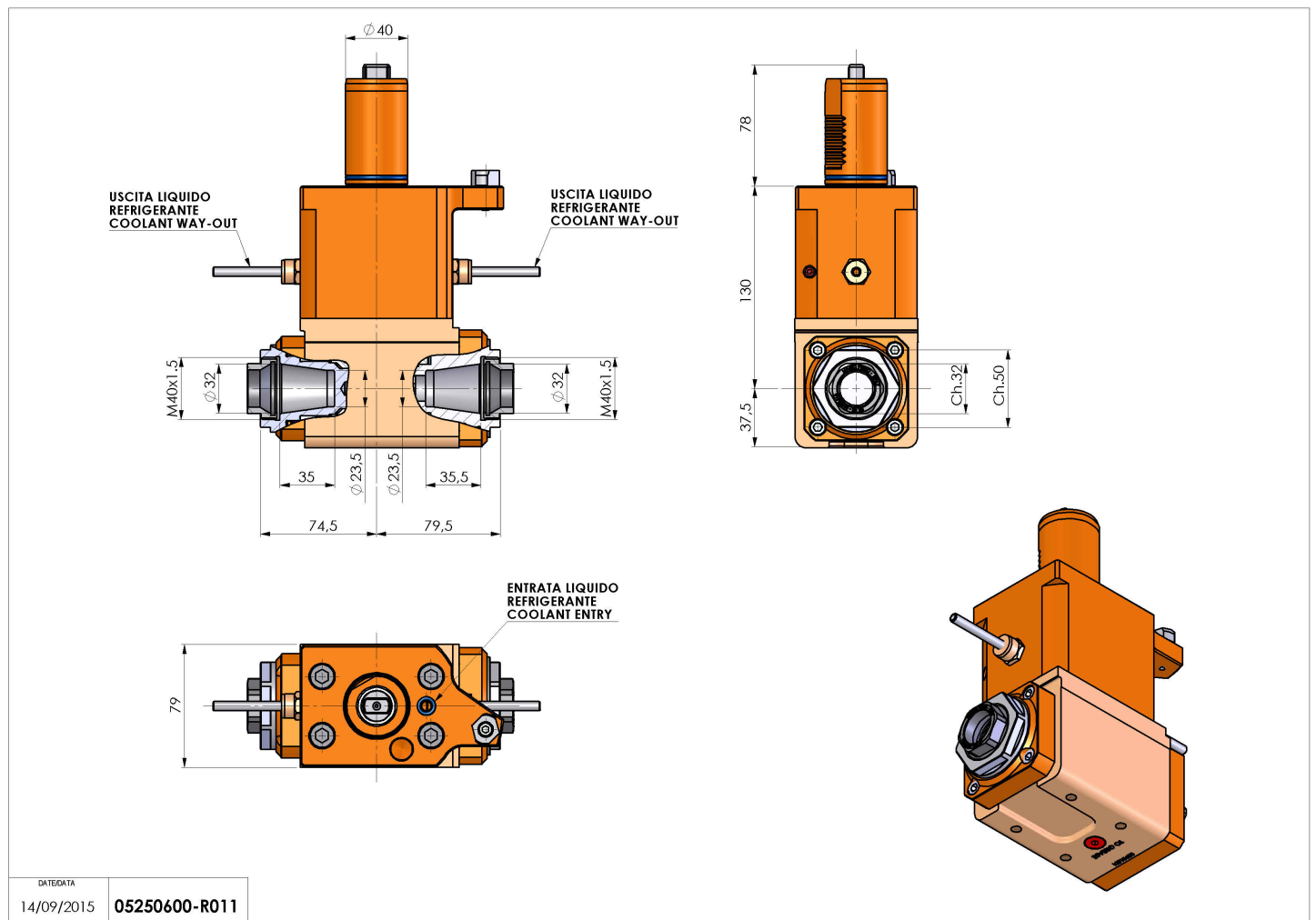

DATE/GRA	05250600-R011
14/09/2015	

Subject to technical changes