

05249300 - LT-A D75 ER40F RF H105

Type	LT-A Tool holder angle 90°
Mounting	CYLINDRICAL SHANK 75
Tool output	Collet nut ER 40 F - internal nut
Coolant	Internal coolant
Direction of rotation	r1 ↻ r2 ↻
Max speed [rpm]	4000
Max torque [Nm]	80
Ratio	1:1
H [mm]	105
H1 [mm]	43
Accessories	N.A.
Notes	N.A.
Mounting tips	Not suitable for every application, please check

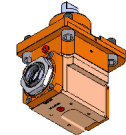

Always check live tool dimensions on the turret

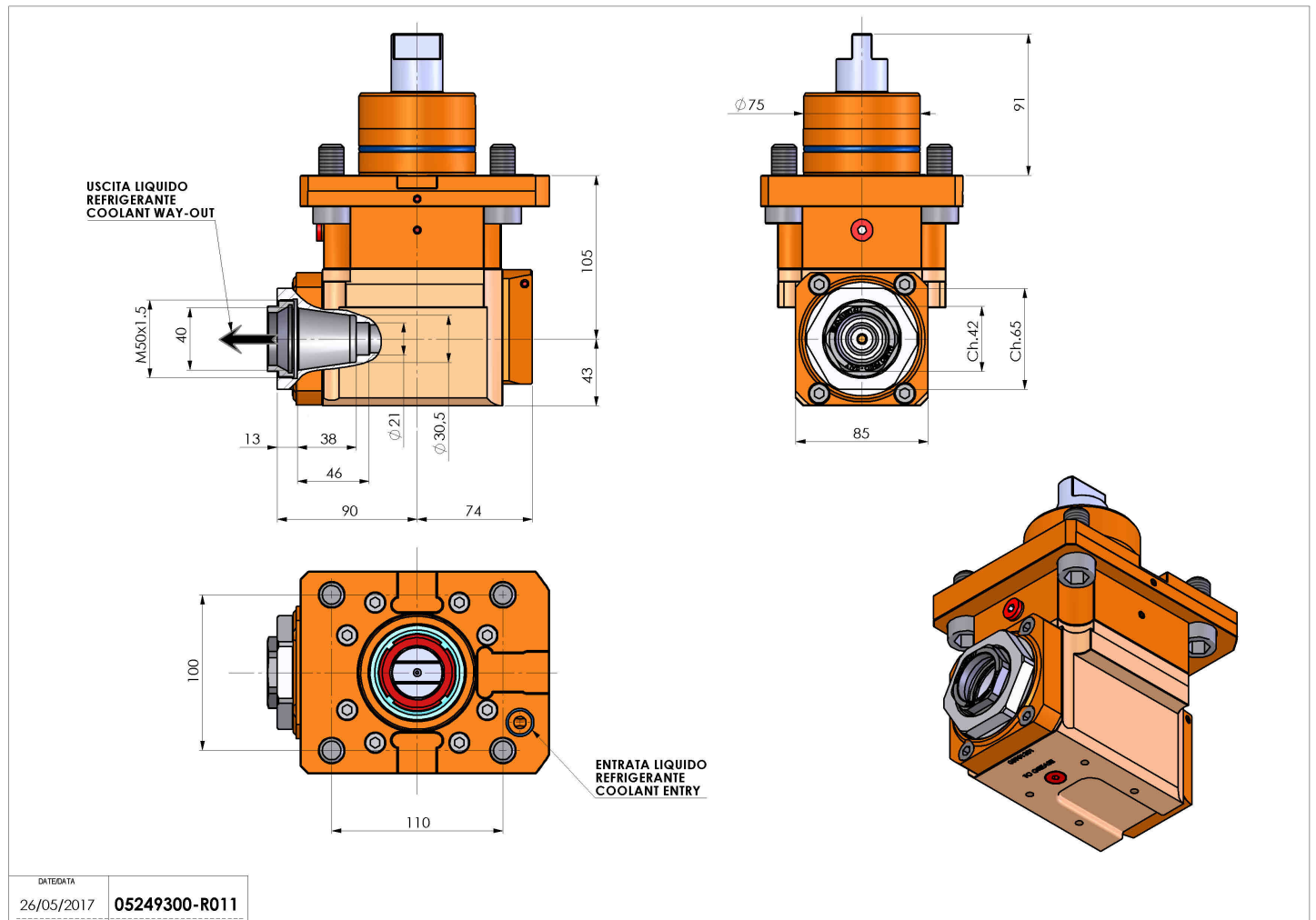

DATE/DATE	05249300-R011
26/05/2017	

Subject to technical changes