

# 05248600 - LT-A VDI50 ER40 OFS LR HRF H90

<b>Type</b>	LT-A OFS Tool holder offset angle 90°
<b>Mounting</b>	VDI 50
<b>Tool output</b>	Collet nut ER 40
<b>Coolant</b>	HP Internal coolant
<b>Direction of rotation</b>	r1  r2
<b>Max speed [rpm]</b>	6000
<b>Max torque [Nm]</b>	50
<b>Ratio</b>	1:1
<b>H [mm]</b>	90
<b>H1 [mm]</b>	43
<b>Max pressure [bar]</b>	80
<b>Accessories</b>	N.A.
<b>Notes</b>	N.A.
<b>Mounting tips</b>	Not suitable for every application, please check

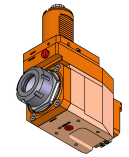

**ATTENZIONE: VERIFICARE L'ORIENTAMENTO DELLA DENTATURA VDI**

Always check live tool dimensions on the turret

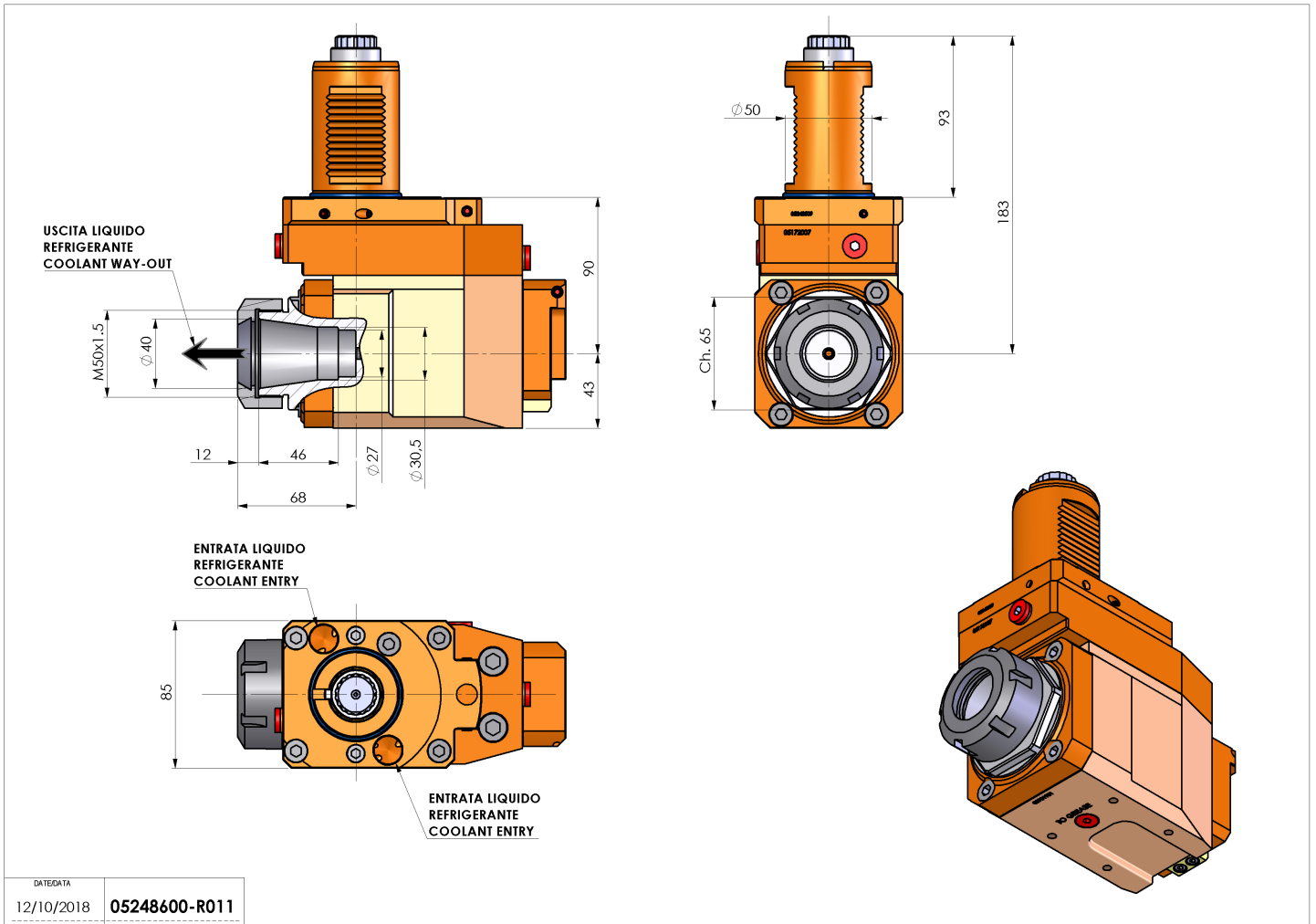

DATE/GATA	12/10/2018	05248600-R011
-----------	------------	---------------

Subject to technical changes