



## 05237100 - LT-S BMT55EM HSK40 H62

<b>Type</b>	LT-S Tool holder straight
<b>Mounting</b>	BMT 55 EM
<b>Tool output</b>	Quick Change HSK40
<b>Coolant</b>	External coolant
<b>Direction of rotation</b>	r1  r2 
<b>Max speed [rpm]</b>	6000
<b>Max torque [Nm]</b>	60
<b>Ratio</b>	1:1
<b>H [mm]</b>	62
<b>Accessories</b>	N.A.
<b>Notes</b>	N.A.
<b>Mounting tips</b>	Not suitable for every application, please check



Always check live tool dimensions on the turret

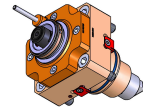
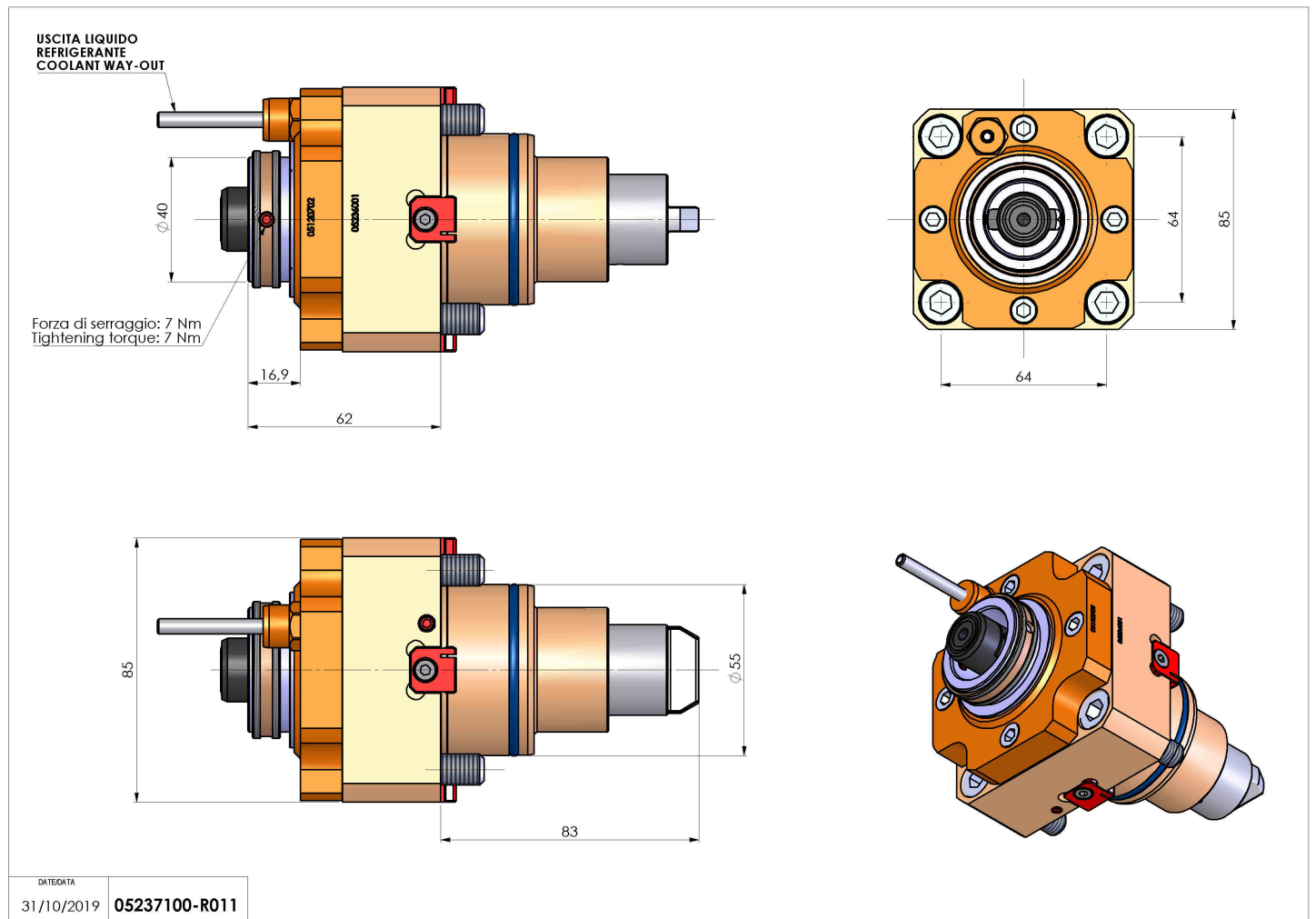

Subject to technical changes