



# 05236400 - LT-A BMT55EM ER32F LR HRF H85

<b>Type</b>	LT-A Tool holder angle 90°
<b>Mounting</b>	BMT 55 EM
<b>Tool output</b>	Collet nut ER 32 F - internal nut
<b>Coolant</b>	HP Internal coolant
<b>Direction of rotation</b>	r1  r2 
<b>Max speed [rpm]</b>	6000
<b>Max torque [Nm]</b>	60
<b>Ratio</b>	1:1
<b>H [mm]</b>	85
<b>H1 [mm]</b>	36
<b>Max pressure [bar]</b>	80
<b>Accessories</b>	N.A.
<b>Notes</b>	N.A.
<b>Mounting tips</b>	Not suitable for every application, please check



Always check live tool dimensions on the turret

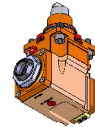
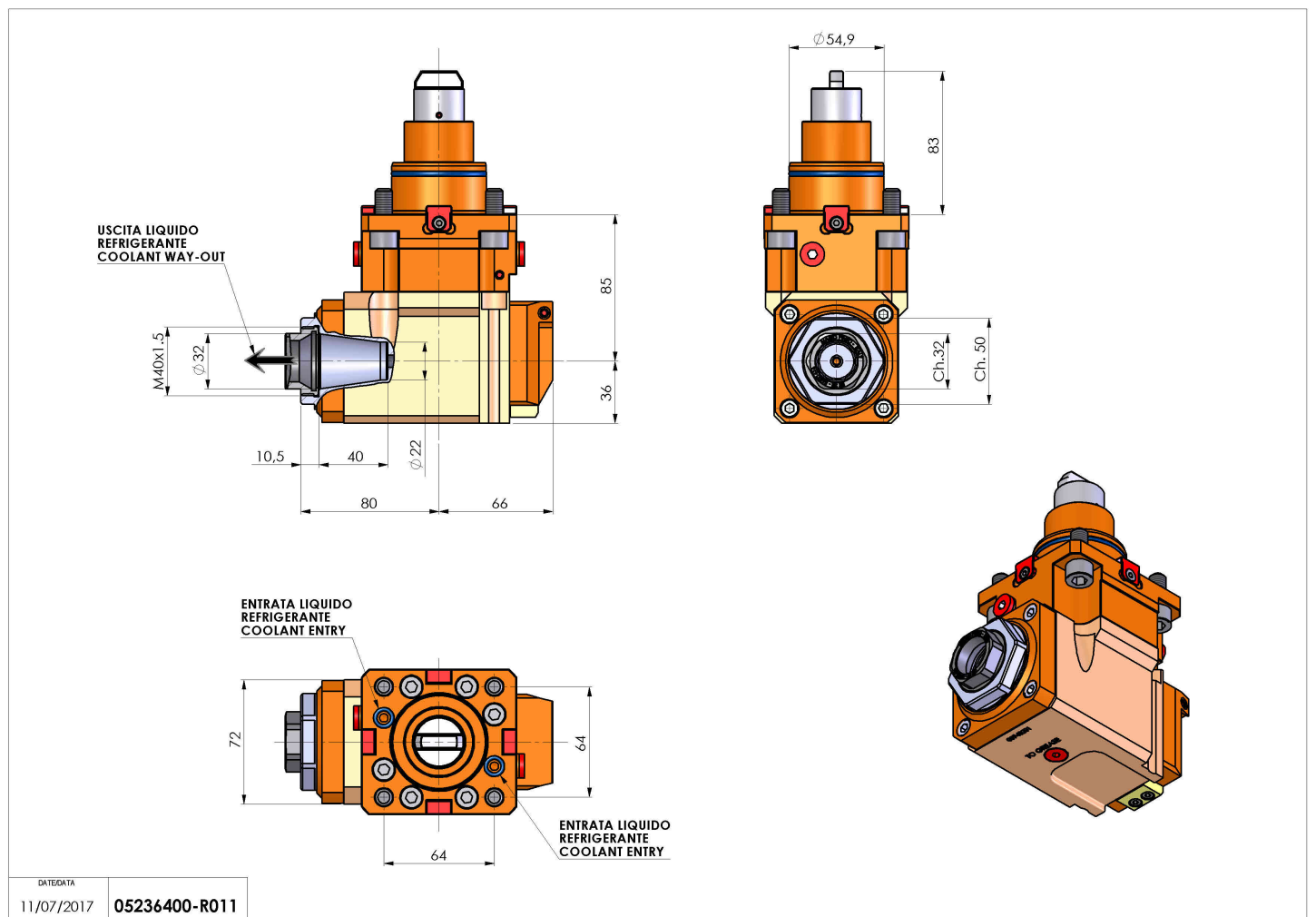

DATE/DATE	11/07/2017	05236400-R011
-----------	------------	---------------

Subject to technical changes