

05232100 - LT-S VDI40 ER20F HRF H83 EM

Type	LT-S Tool holder straight
Mounting	VDI 40
Tool output	Collet nut ER 20 F - internal nut
Coolant	HP Internal coolant
Direction of rotation	r1 ↻ r2 ↻
Max speed [rpm]	10000
Max torque [Nm]	63
Ratio	1:1
H [mm]	83
Max pressure [bar]	70
Accessories	N.A.
Notes	N.A.
Mounting tips	Not suitable for every application, please check

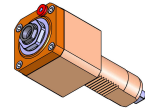

ATTENZIONE: VERIFICARE L'ORIENTAMENTO DELLA DENTATURA VDI

Always check live tool dimensions on the turret

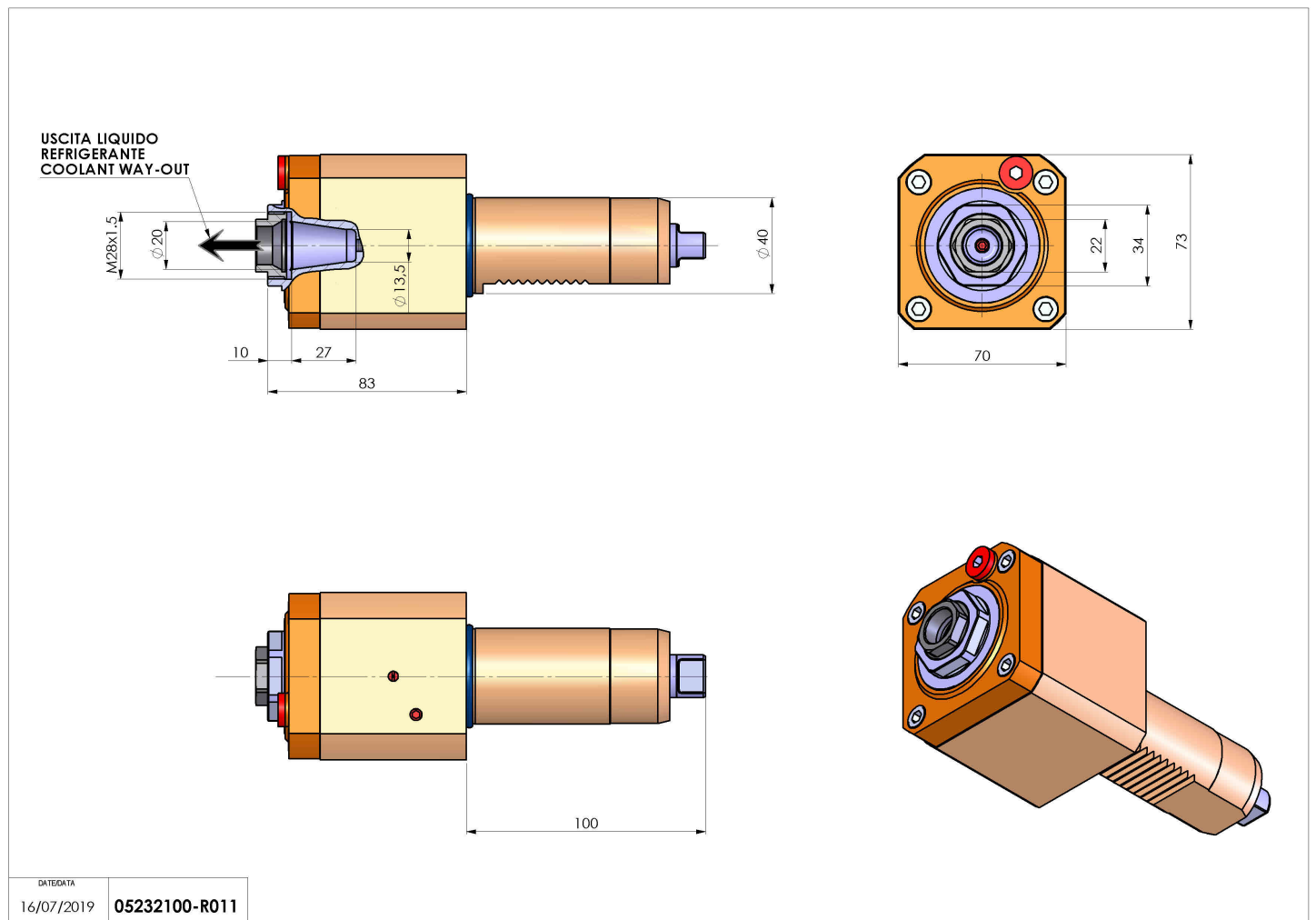

Subject to technical changes