

# 05226000 - LT-A D35 HSK40 OFS H100 5480SA

<b>Type</b>	LT-A OFS Tool holder offset angle 90°
<b>Mounting</b>	CYLINDRICAL SHANK 35
<b>Tool output</b>	Quick Change HSK40
<b>Coolant</b>	External coolant
<b>Direction of rotation</b>	r1  r2
<b>Max speed [rpm]</b>	6000
<b>Max torque [Nm]</b>	63
<b>Ratio</b>	1:1
<b>H [mm]</b>	100
<b>H1 [mm]</b>	36
<b>Accessories</b>	N.A.
<b>Notes</b>	N.A.
<b>Mounting tips</b>	Not suitable for every application, please check

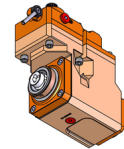

Always check live tool dimensions on the turret

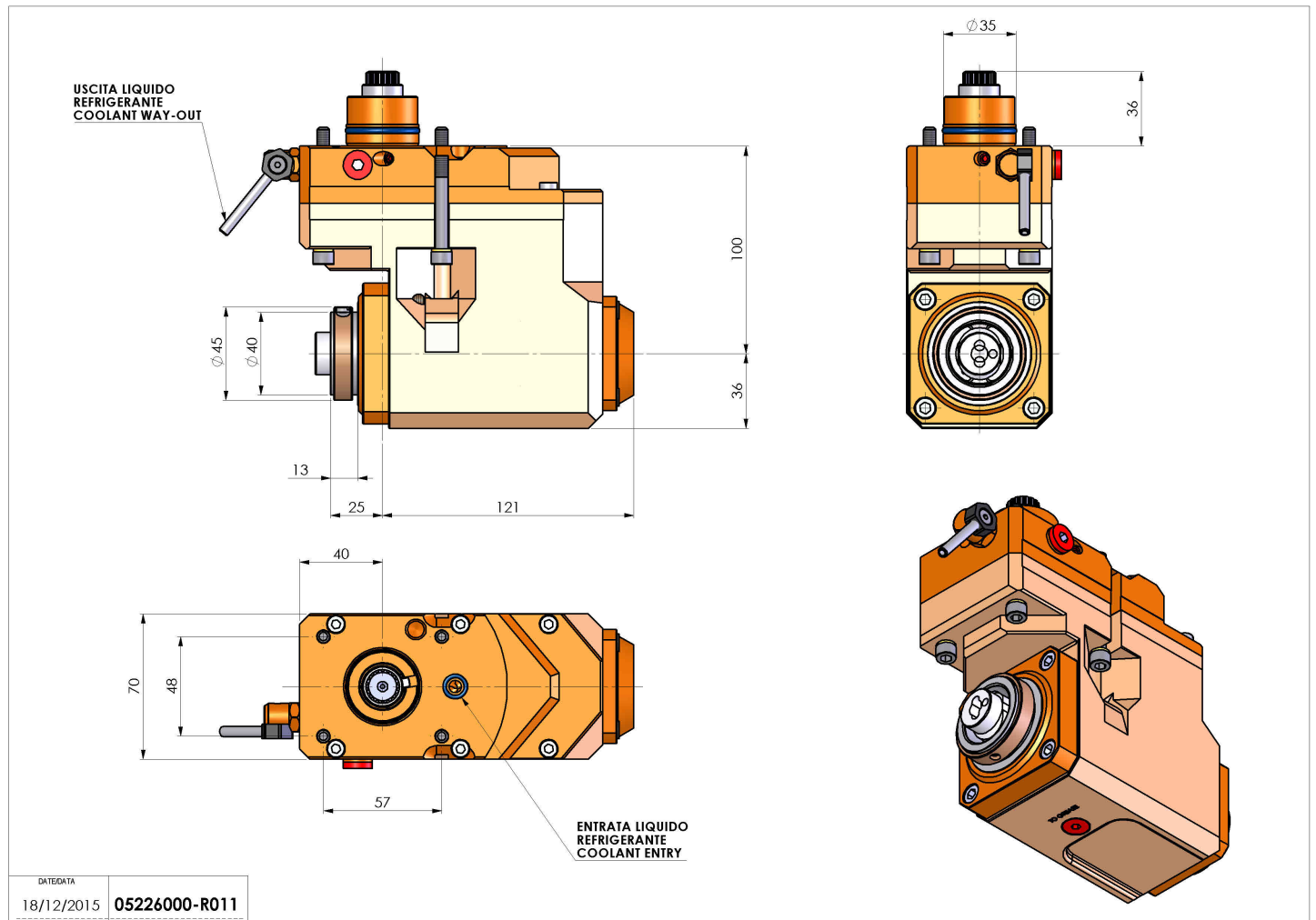

DATE/DATE	18/12/2015	05226000-R011
-----------	------------	---------------

Subject to technical changes