

05225100 - LT-A VDI50 DIN138-27H1105480SA

Type	LT-A Tool holder angle 90°
Mounting	VDI 50
Tool output	Shell-Mill DIN138 27
Coolant	External coolant
Direction of rotation	r1 ↻ r2 ↻
Max speed [rpm]	6000
Max torque [Nm]	63
Ratio	1:1
H [mm]	110
H1 [mm]	43
Accessories	N.A.
Notes	N.A.

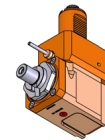

Mounting tips Not suitable for every application, please check

ATTENZIONE: VERIFICARE L'ORIENTAMENTO DELLA DENTATURA VDI

Always check live tool dimensions on the turret

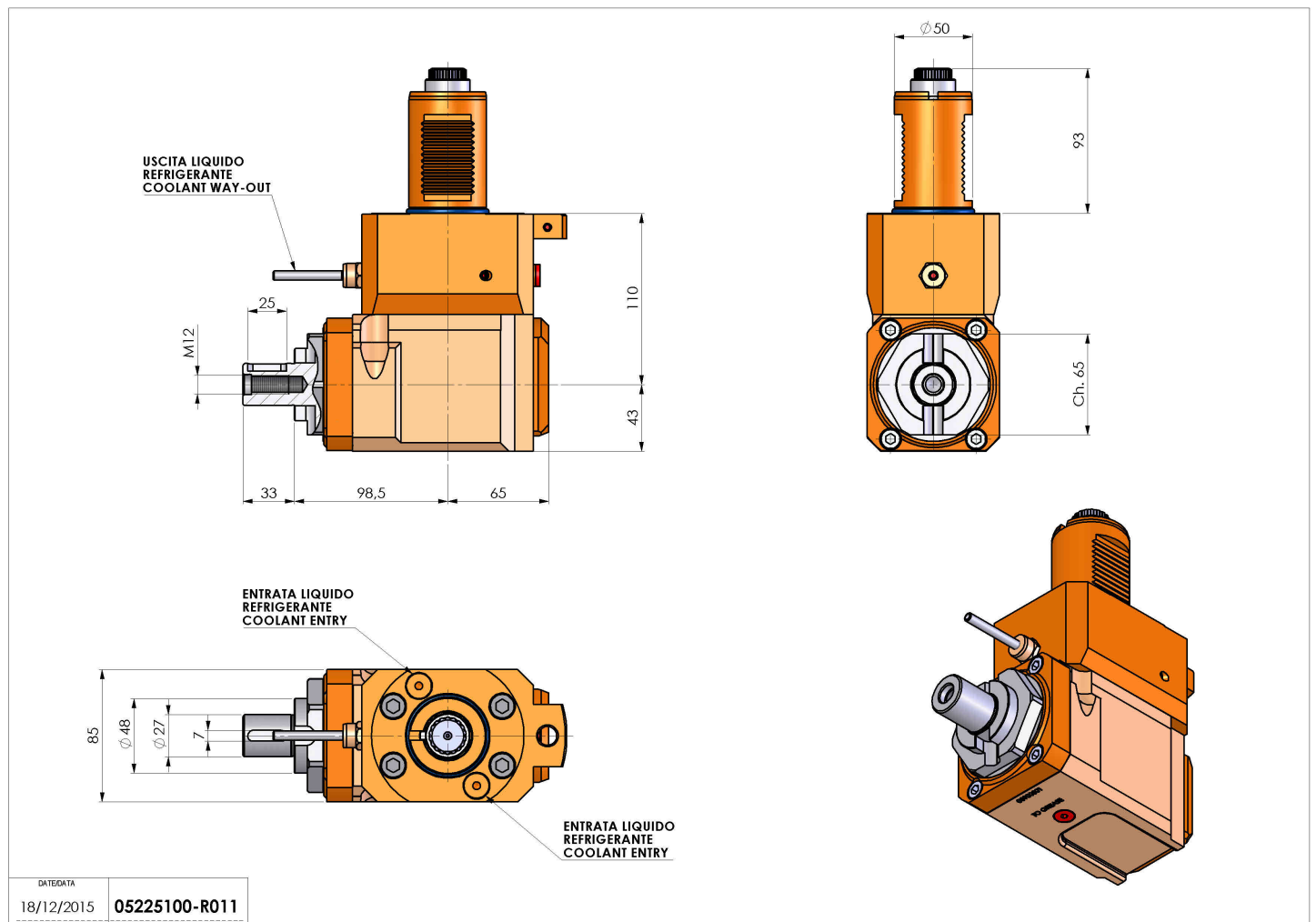

DATE/DATE	18/12/2015	05225100-R011
-----------	------------	---------------

Subject to technical changes