

05177100 - LT-A VDI50 ER40F RF OFS H90 BA

| | |
|-----------------------|--|
| Type | LT-A OFS Tool holder offset angle 90° |
| Mounting | VDI 50 |
| Tool output | Collet nut ER 40 F - internal nut |
| Coolant | Internal coolant |
| Direction of rotation | r1 ↻ r2 ↻ |
| Max speed [rpm] | 6000 |
| Max torque [Nm] | 50 |
| Ratio | 1:1 |
| H [mm] | 90 |
| H1 [mm] | 43 |
| Accessories | N.A. |
| Notes | N.A. |
| Mounting tips | Not suitable for every application, please check |

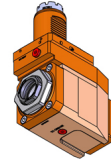

ATTENZIONE: VERIFICARE L'ORIENTAMENTO DELLA DENTATURA VDI

Always check live tool dimensions on the turret

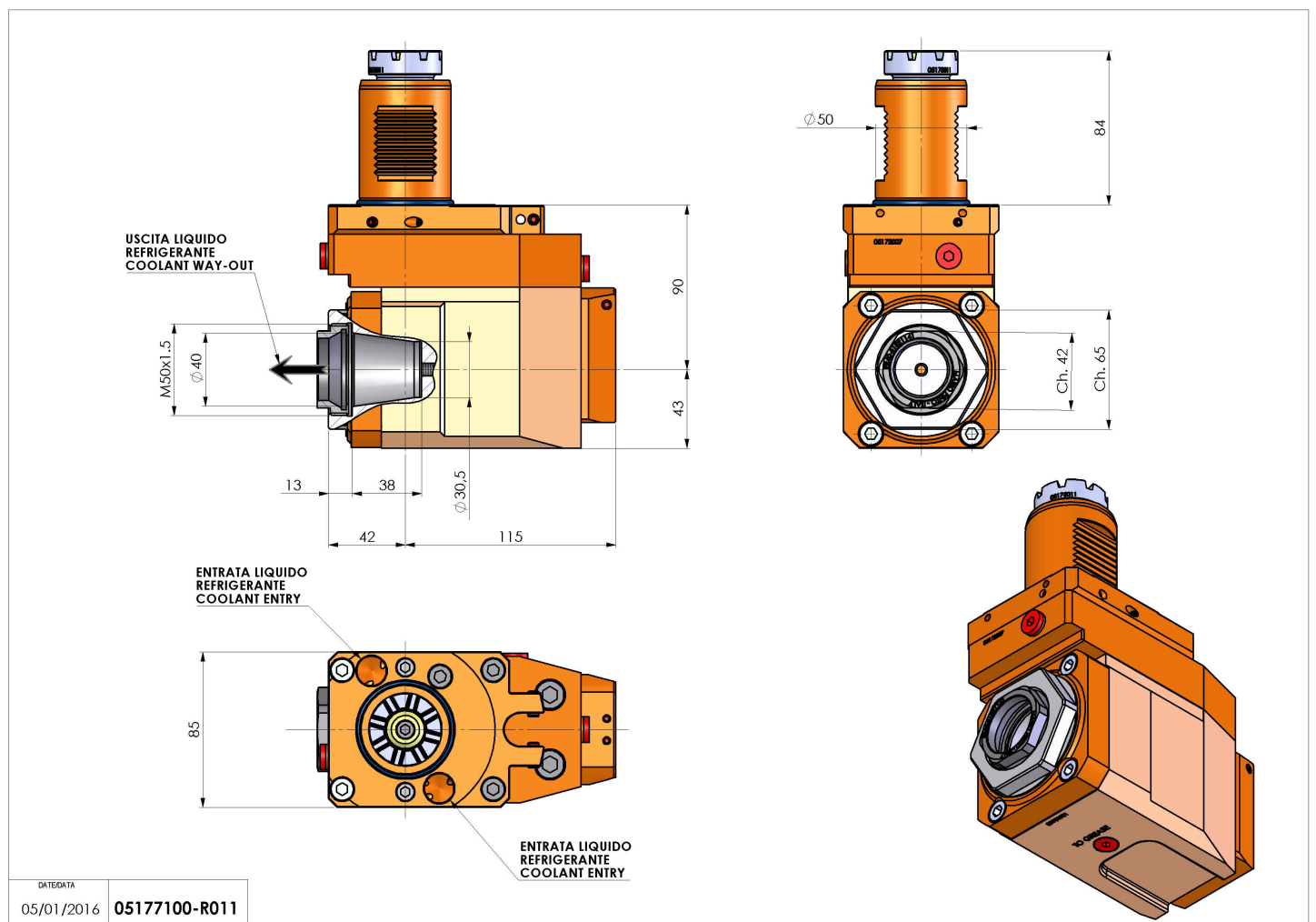

DATE/DATE 05/01/2016 **05177100-R011**

Subject to technical changes