



05165500 - LT-S D44 ER20F OFS49.5 HRF H65

Type	LT-S OFS Tool holder straight offset
Mounting	CYLINDRICAL SHANK 44
Tool output	Collet nut ER 20 F - internal nut
Coolant	HP Internal coolant
Direction of rotation	r1  r2 
Max speed [rpm]	6000
Max torque [Nm]	30
Ratio	1:1
H [mm]	65
Max pressure [bar]	80
Accessories	N.A.
Notes	N.A.
Mounting tips	Not suitable for every application, please check



Always check live tool dimensions on the turret

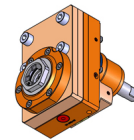
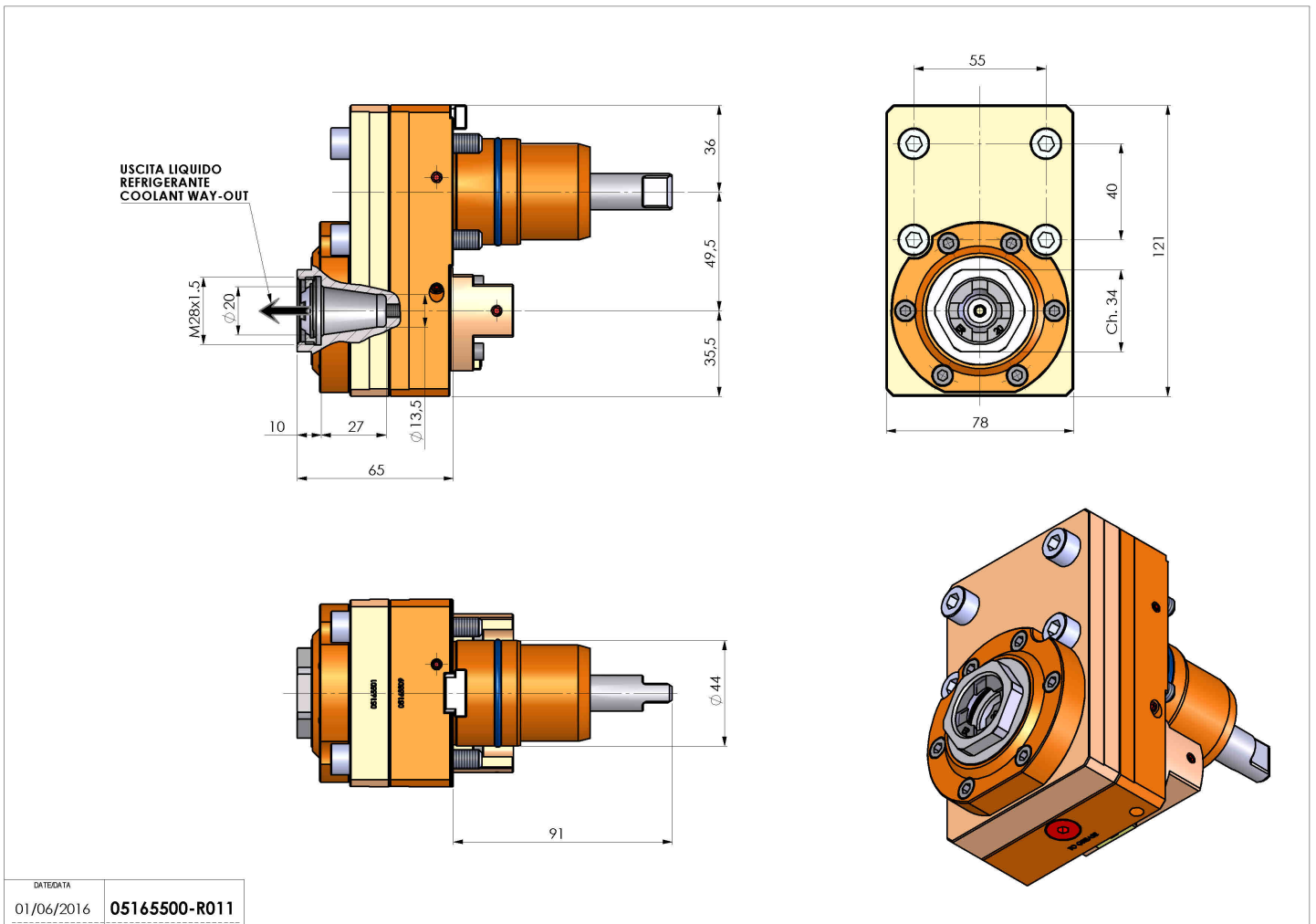

DATE/DATE	01/06/2016	05165500-R011
-----------	------------	---------------

Subject to technical changes