



# 05161400 - LT-S D35ER20FOFS38.25 2:1H95MU

<b>Type</b>	LT-S OFS Tool holder straight offset
<b>Mounting</b>	CYLINDRICAL SHANK 35
<b>Tool output</b>	Collet nut ER 20 F - internal nut
<b>Coolant</b>	External coolant
<b>Offset [mm]</b>	38,25
<b>Direction of rotation</b>	r1  r2 
<b>Max speed [rpm]</b>	in 6000 / out 3000
<b>Max torque [Nm]</b>	in 10 / out 20
<b>Ratio</b>	2:1
<b>H [mm]</b>	95
<b>Accessories</b>	N.A.
<b>Notes</b>	N.A.
<b>Mounting tips</b>	Not suitable for every application, please check



Always check live tool dimensions on the turret

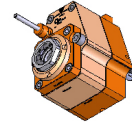
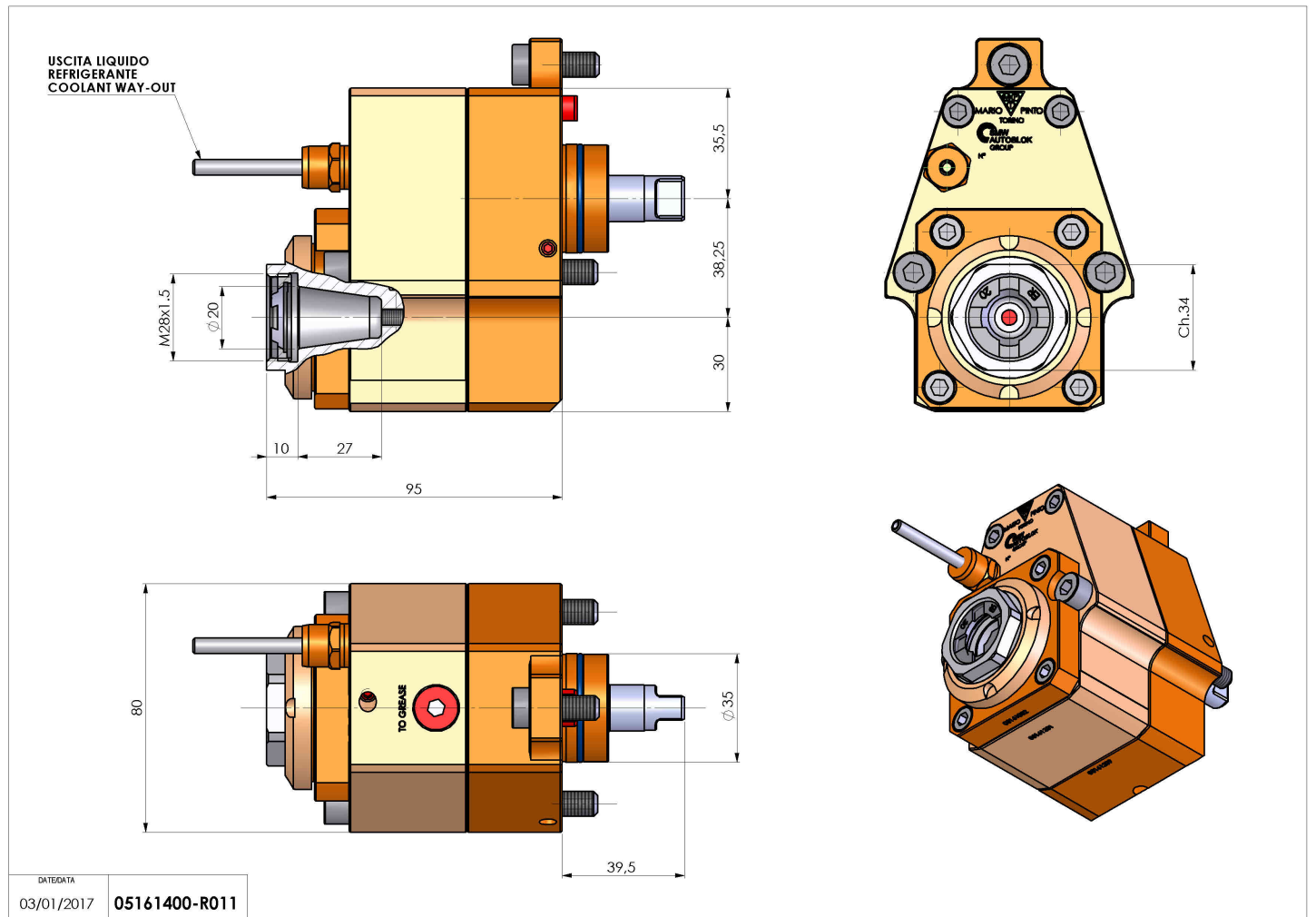

Subject to technical changes