

05161000 - LT-S D35ER20FOF38.25RF1:2H95MU

Type	LT-S OFS Tool holder straight offset
Mounting	CYLINDRICAL SHANK 35
Tool output	Collet nut ER 20 F - internal nut
Coolant	Internal coolant
Offset [mm]	38,25
Direction of rotation	r1 r2
Max speed [rpm]	in 6000 / out 12000
Max torque [Nm]	in 10 / out 5
Ratio	1:2
H [mm]	95
Accessories	N.A.
Notes	N.A.
Mounting tips	Not suitable for every application, please check

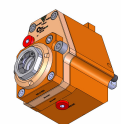

Always check live tool dimensions on the turret

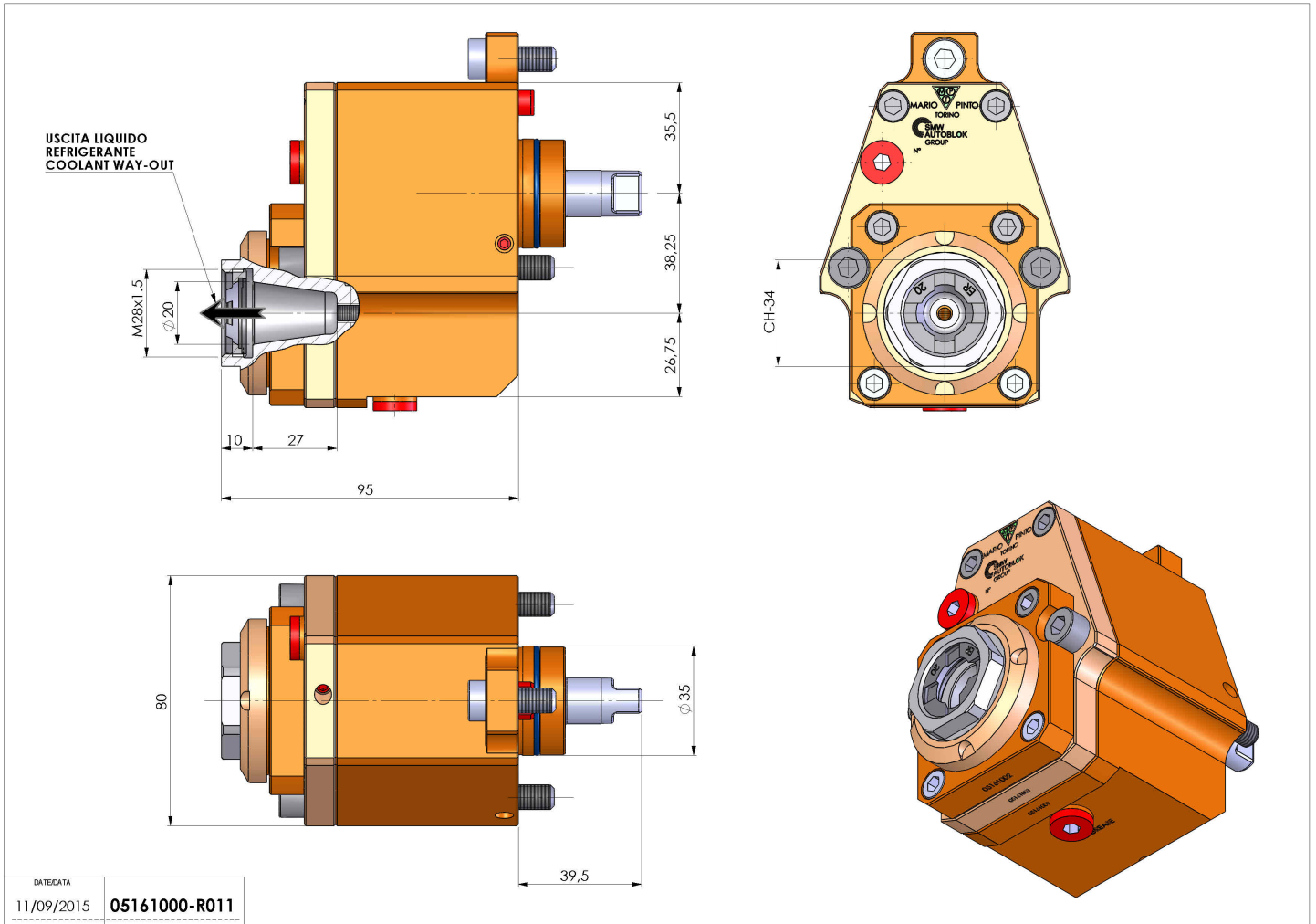

Subject to technical changes