

05156200 - LT-SAW D40 16-22-27 1:1 H90 MU

Type	LT-HOB-SAW Hobbing/tool holder saw
Mounting	CYLINDRICAL SHANK 40
Tool output	Shank kit Ø16-Ø22-Ø27
Coolant	External coolant
Max speed [rpm]	6000
Max torque [Nm]	60
Ratio	1:1
H [mm]	90
Accessories	N.A.
Notes	N.A.
Mounting tips	Not suitable for every application, please check

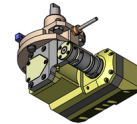

Always check live tool dimensions on the turret

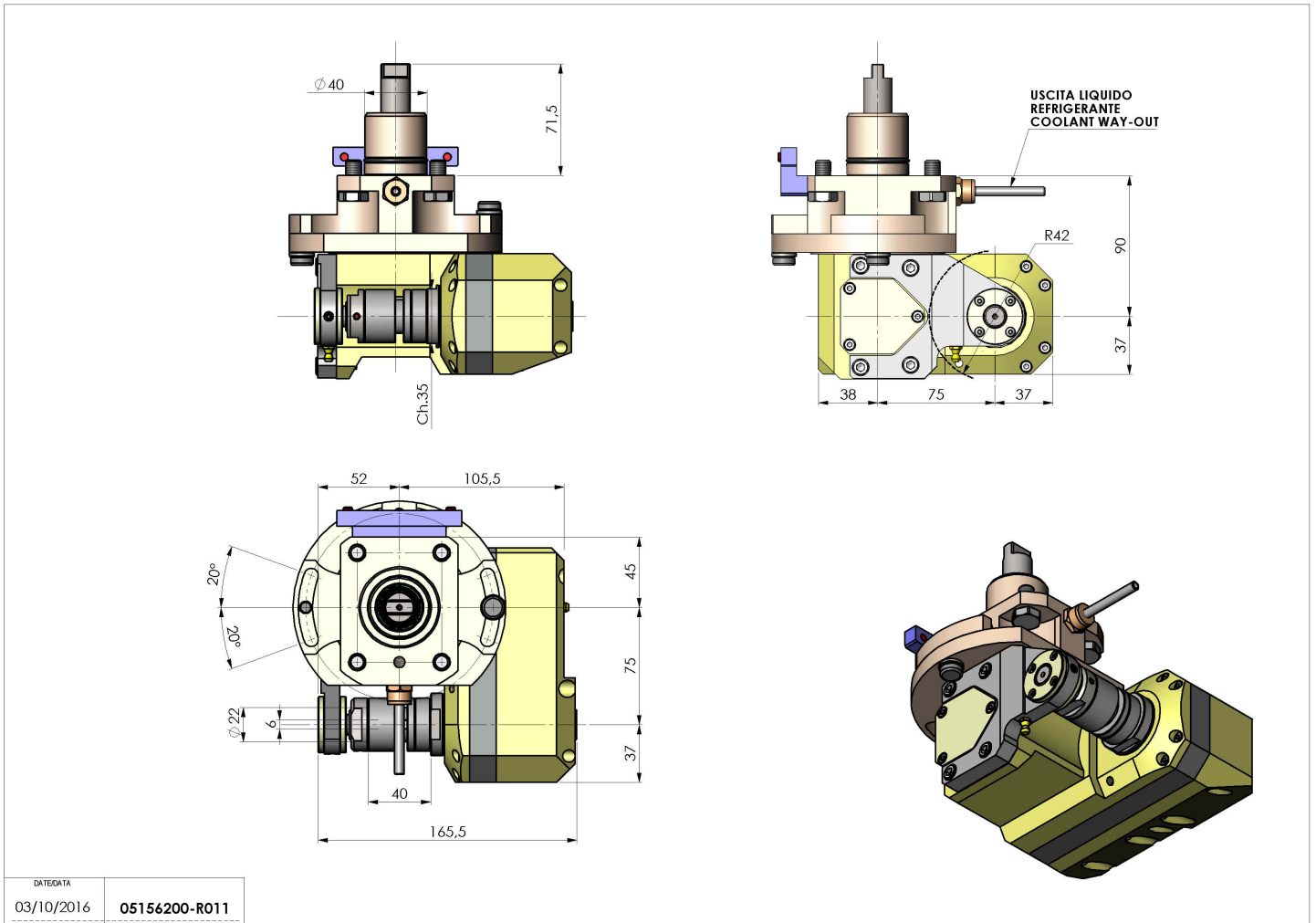

DATE/DATE	
03/10/2016	05156200-R011

Subject to technical changes