

05153400 - LT-S D40 WELDON-20 RF H108 MU

Type	LT-S Tool holder straight
Mounting	CYLINDRICAL SHANK 40
Tool output	Weldon 20 DIN1835B
Coolant	Internal coolant
Direction of rotation	r1 r2
Max speed [rpm]	6000
Max torque [Nm]	63
Ratio	1:1
H [mm]	108
Accessories	
Notes	N.A.
Mounting tips	Not suitable for every application, please check

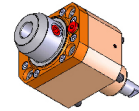

Always check live tool dimensions on the turret

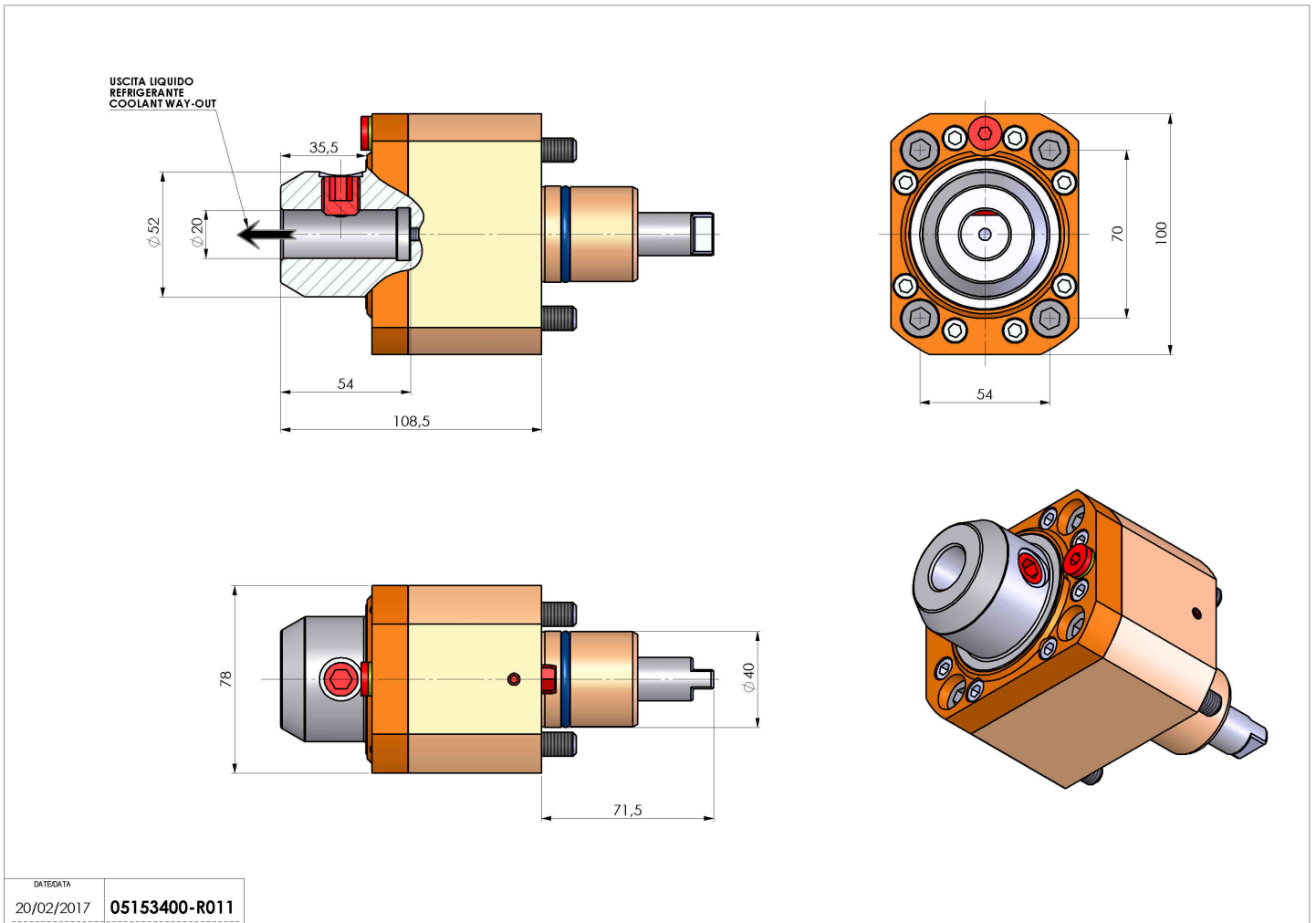

DATE/DATE	
20/02/2017	05153400-R011

Subject to technical changes