

## 05152200 - LT-S VDI40 C40 H82.5

<b>Type</b>	LT-S Tool holder straight
<b>Mounting</b>	VDI 40
<b>Tool output</b>	Polygonal shank C40 ISO 26623-1
<b>Coolant</b>	External coolant
<b>Direction of rotation</b>	r1  r2
<b>Max speed [rpm]</b>	6000
<b>Max torque [Nm]</b>	63
<b>Ratio</b>	1:1
<b>H [mm]</b>	82.5
<b>Accessories</b>	N.A.
<b>Notes</b>	N.A.
<b>Mounting tips</b>	Not suitable for every application, please check

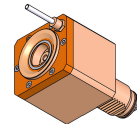

**ATTENZIONE: VERIFICARE L'ORIENTAMENTO DELLA DENTATURA VDI**

Always check live tool dimensions on the turret

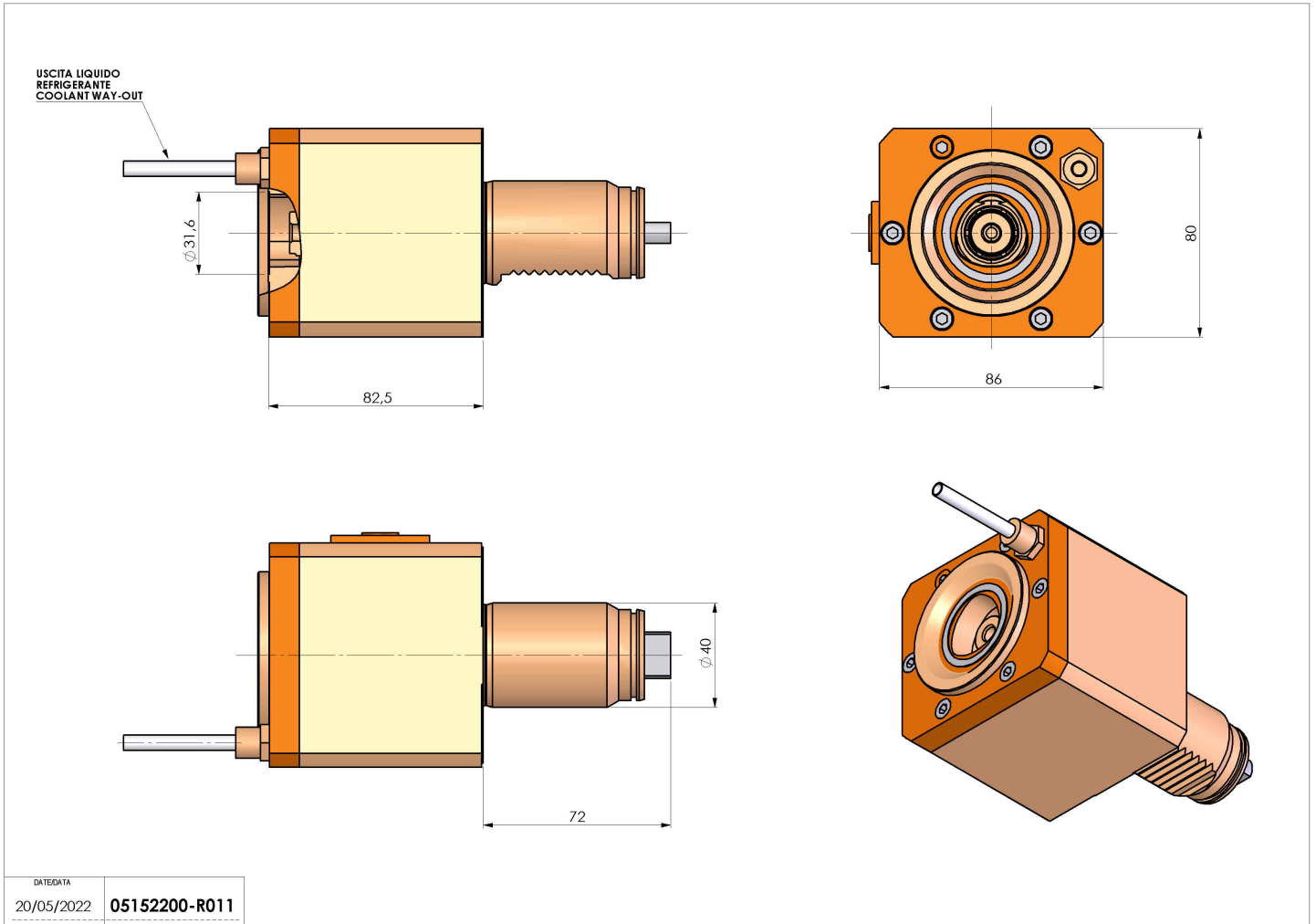

DATE/DATE	20/05/2022	05152200-R011
-----------	------------	---------------

**Subject to technical changes**