

05150900 - LT-A VDI40M DIN-22 L H110 MU

| | |
|-----------------------|--|
| Type | LT-A Tool holder angle 90° |
| Mounting | VDI 40 |
| Tool output | Shell-Mill DIN138 22 |
| Coolant | External coolant |
| Direction of rotation | r1 ↻ r2 ↻ |
| Max speed [rpm] | 6000 |
| Max torque [Nm] | 63 |
| Ratio | 1:1 |
| H [mm] | 110 |
| H1 [mm] | 38 |
| Accessories | N.A. |
| Notes | N.A. |
| Mounting tips | Not suitable for every application, please check |

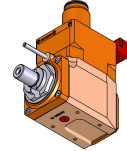

ATTENZIONE: VERIFICARE L'ORIENTAMENTO DELLA DENTATURA VDI

Always check live tool dimensions on the turret

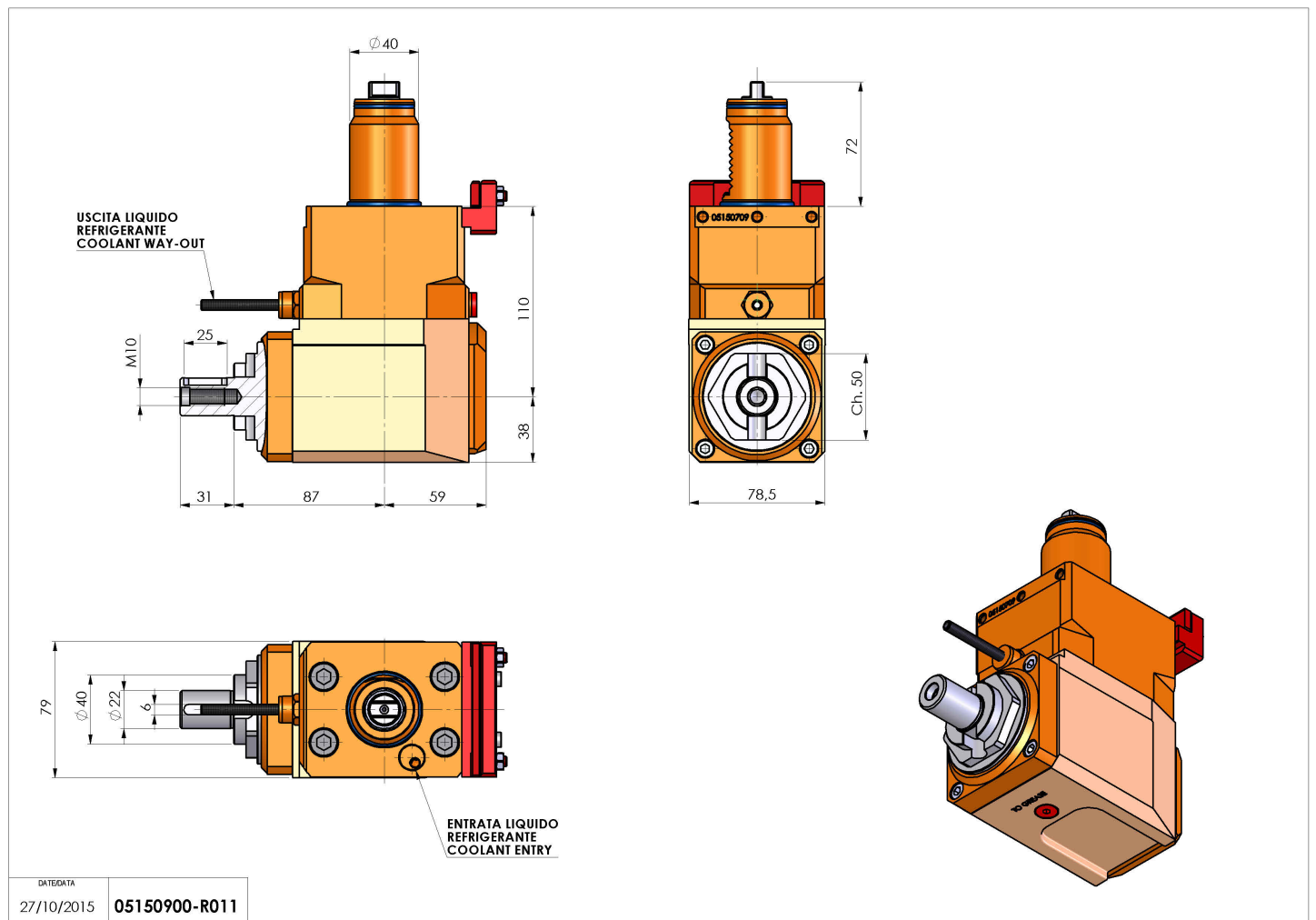

| | |
|------------|---------------|
| DATE/GATA | 05150900-R011 |
| 27/10/2015 | |

Subject to technical changes