



05133000 - LT-T BMT65 ER20F H71-151 G HK

Type	LT-T Tool holder tiltable
Mounting	BMT 65
Tool output	Collet nut ER 20 F - internal nut
Coolant	External coolant
Direction of rotation	r1  r2 
Max speed [rpm]	6000
Max torque [Nm]	20
Ratio	1:1
H [mm]	70,5-118,5
Accessories	N.A.
Notes	N.A.
Mounting tips	Not suitable for every application, please check



Always check live tool dimensions on the turret

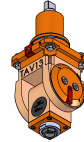
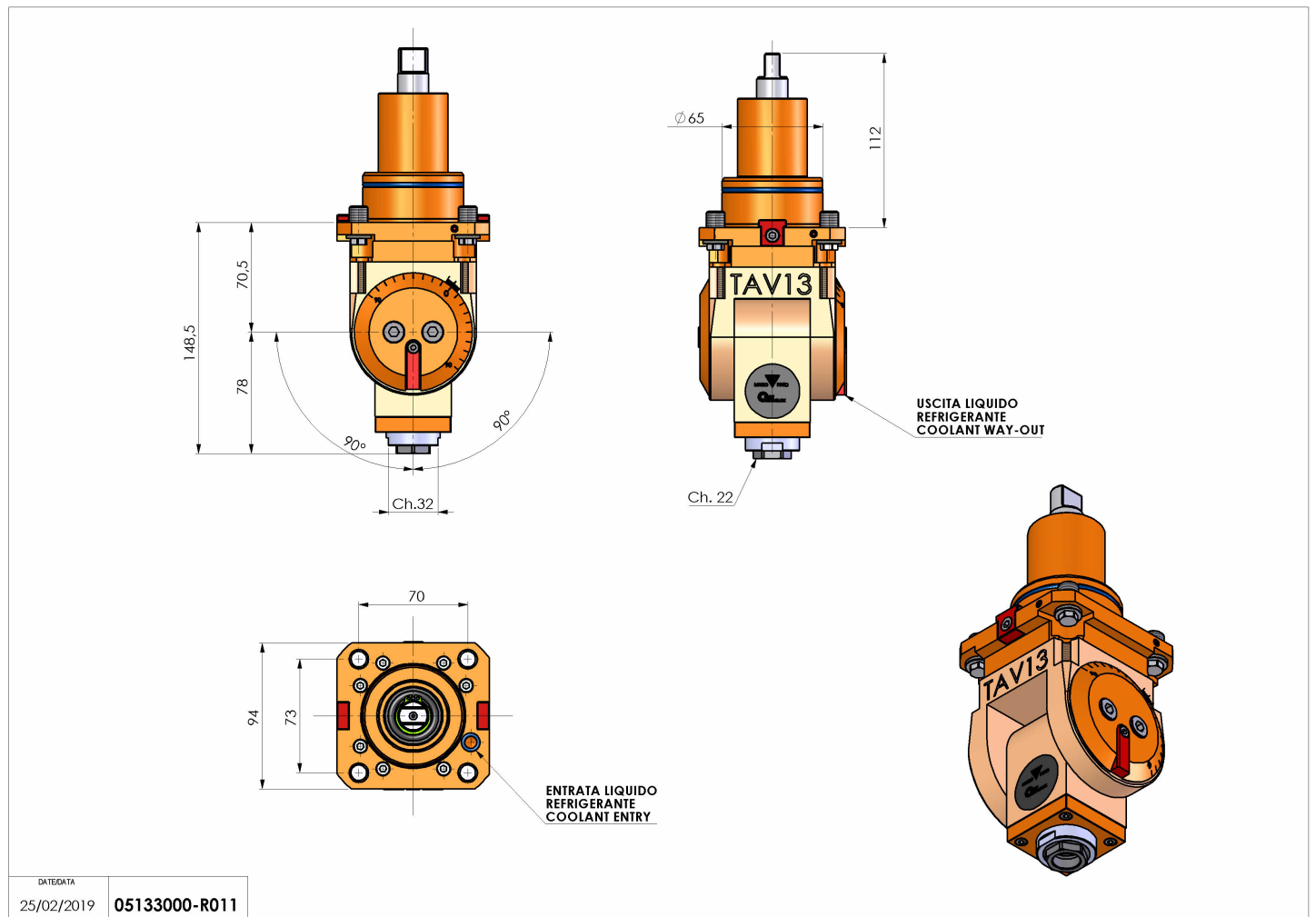

DATE/DATE
25/02/2019 05133000-R011

Subject to technical changes