

05091300 - LT-A D30 DIN138-22 L-R H75 RO

Type	LT-A Tool holder angle 90°
Mounting	CYLINDRICAL SHANK 30
Tool output	Shell-Mill DIN138 22
Coolant	External coolant
Direction of rotation	r1 ↻ r2 ↻
Max speed [rpm]	6000
Max torque [Nm]	63
Ratio	1:1
H [mm]	75
H1 [mm]	40
Accessories	N.A.
Notes	N.A.
Mounting tips	Not suitable for every application, please check

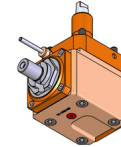

Always check live tool dimensions on the turret

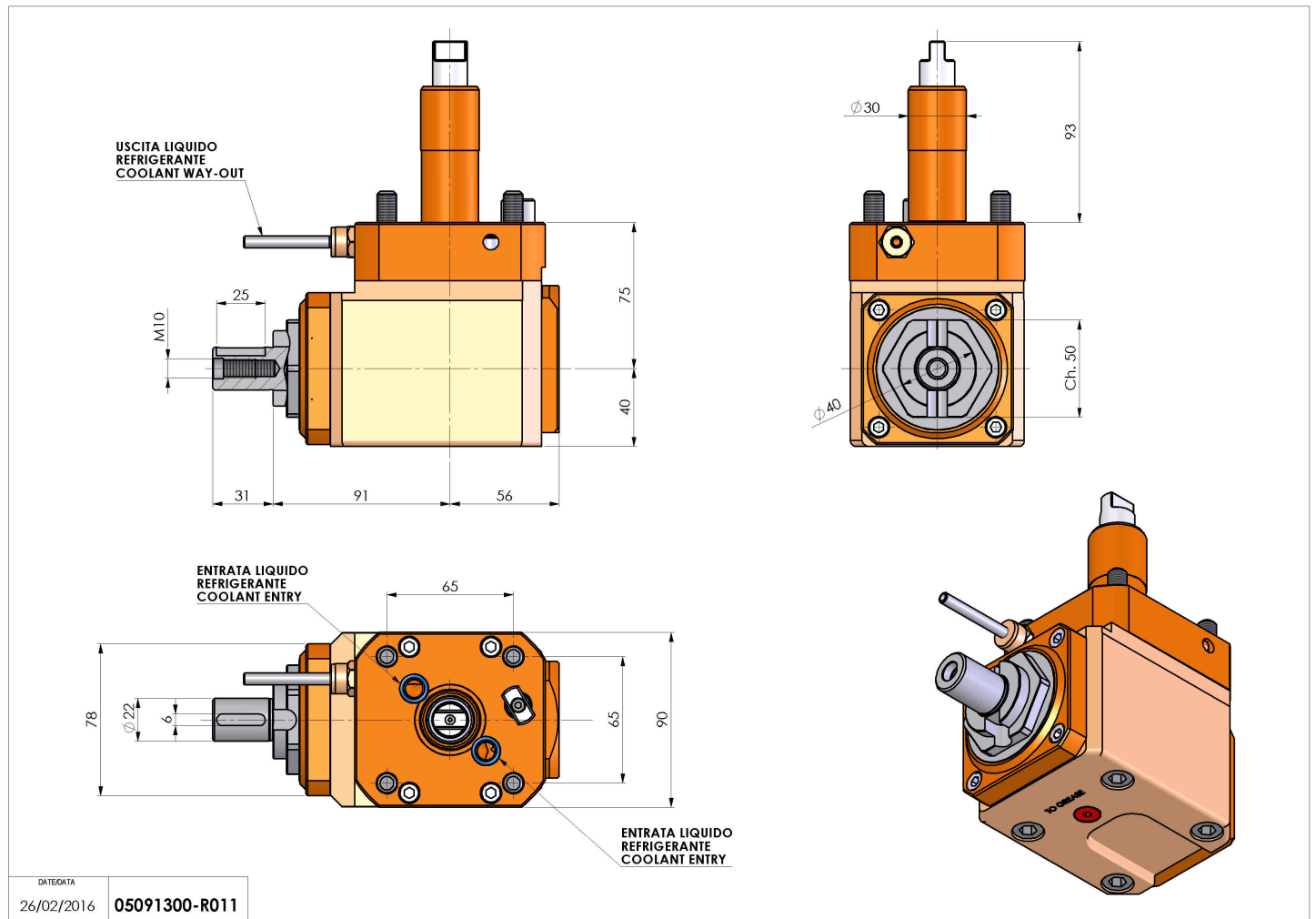

Subject to technical changes