

05090100 - LT-S D25 DIN138-16 H65 ROMI

Type	LT-S Tool holder straight
Mounting	CYLINDRICAL SHANK 25
Tool output	Shell-Mill DIN138 16
Coolant	External coolant
Direction of rotation	r1 r2
Max speed [rpm]	6000
Max torque [Nm]	40
Ratio	1:1
H [mm]	65,5
Accessories	
Notes	N.A.
Mounting tips	Not suitable for every application, please check

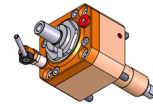

Always check live tool dimensions on the turret

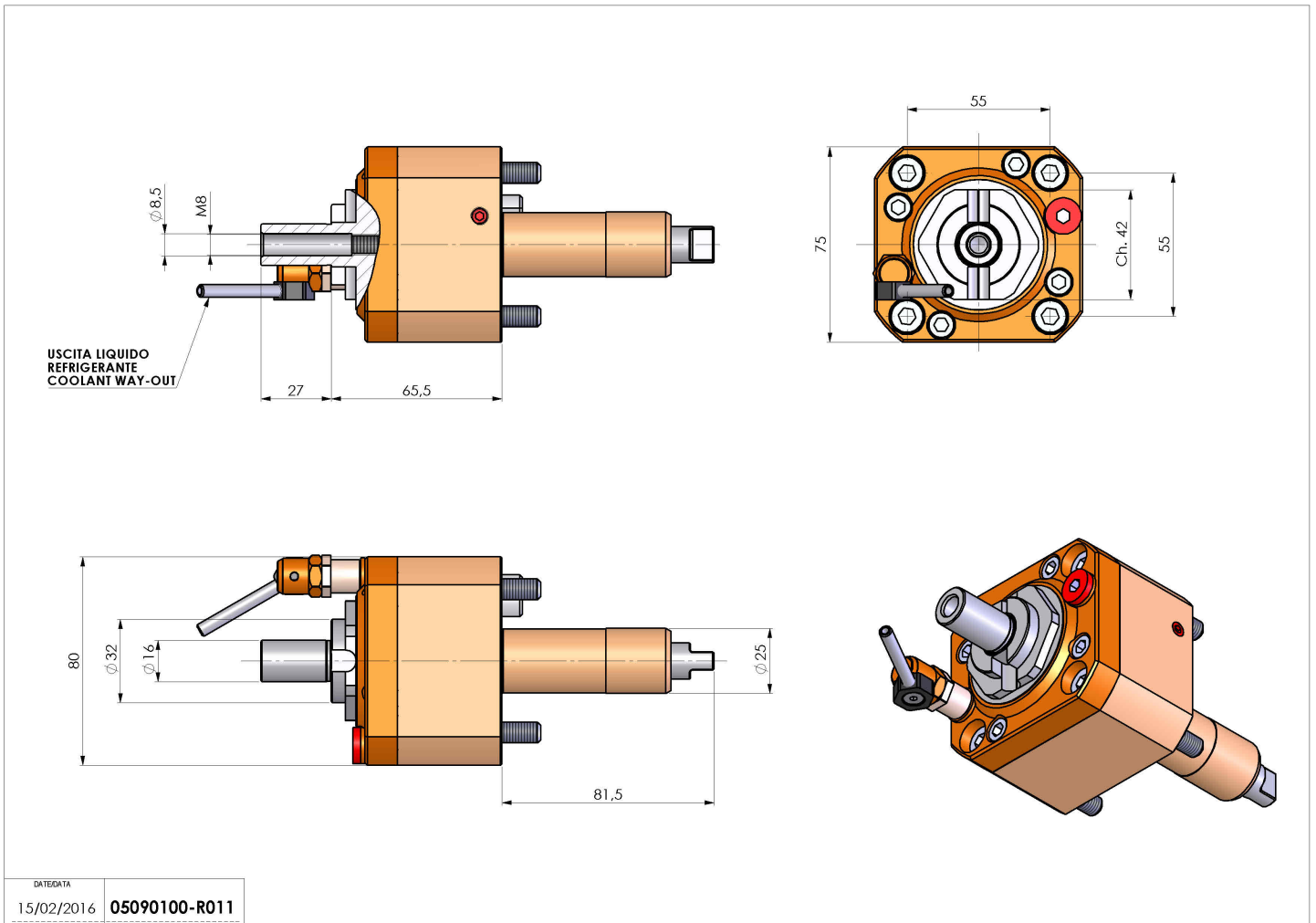

DATE DATA	15/02/2016
PART NUMBER	05090100-R011

Subject to technical changes