



05081900 - LT-S D30 DIN138-16 H67 AN

Type	LT-S Tool holder straight
Mounting	CYLINDRICAL SHANK 30
Tool output	Shell-Mill DIN138 16
Coolant	External coolant
Direction of rotation	r1  r2 
Max speed [rpm]	6000
Max torque [Nm]	40
Ratio	1:1
H [mm]	67
Accessories	
Notes	N.A.
Mounting tips	Not suitable for every application, please check



Always check live tool dimensions on the turret

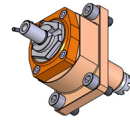
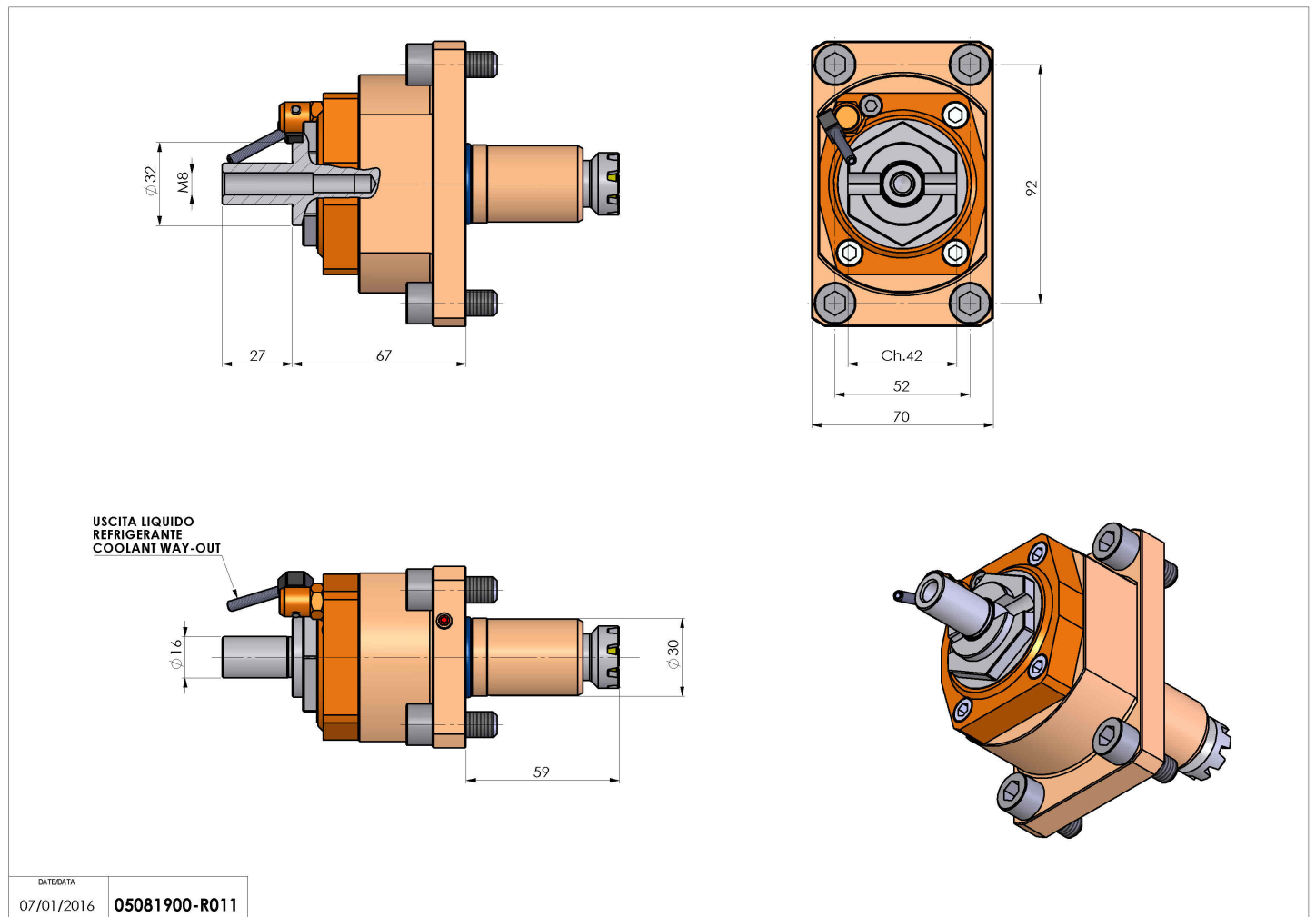

DATE/DATE	07/01/2016
	05081900-R011

Subject to technical changes