

05078200 - LT-A D55 WELDON 16-16 LR H100

Type	LT-A DBL Tool holder double angle 90°
Mounting	CYLINDRICAL SHANK 55
Tool output	Weldon 16 DIN1835B
Coolant	External coolant
Direction of rotation	r1 r2 r3
Max speed [rpm]	6000
Max torque [Nm]	63
Ratio	1:1
H [mm]	100
H1 [mm]	38
Accessories	N.A.
Notes	N.A.
Mounting tips	Not suitable for every application, please check

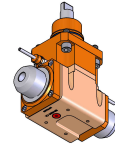

Always check live tool dimensions on the turret

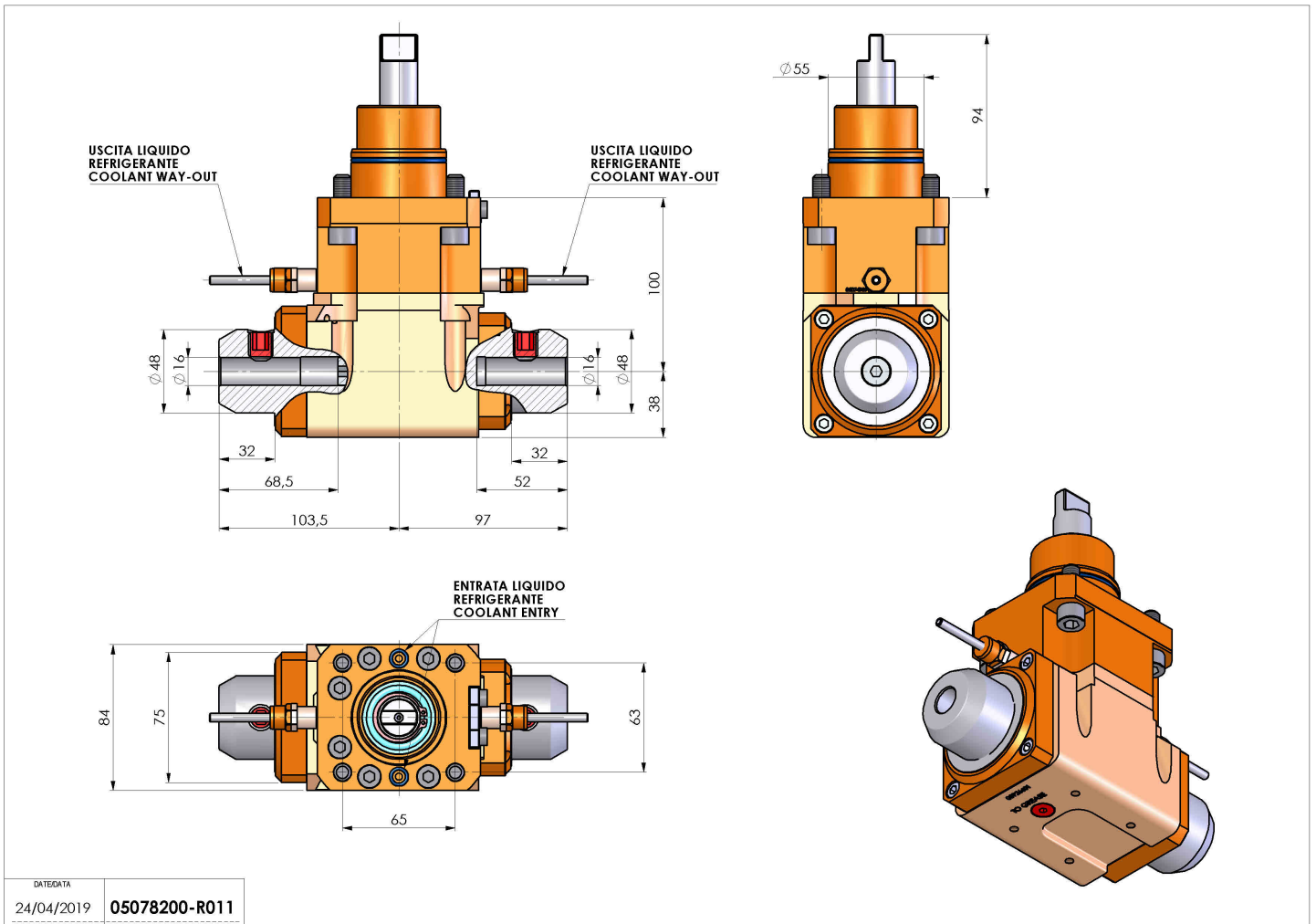

DATE/DATA	24/04/2019
PART NUMBER	05078200-R011

Subject to technical changes