

05069100 - LT-S D60 ER40 H85 OK

Type	LT-S Tool holder straight
Mounting	CYLINDRICAL SHANK 60
Tool output	Collet nut ER 40
Coolant	External coolant
Direction of rotation	r1 r2
Max speed [rpm]	6000
Max torque [Nm]	100
Ratio	1:1
H [mm]	85
Accessories	
Notes	N.A.
Mounting tips	Not suitable for every application, please check

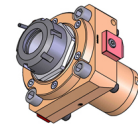

Always check live tool dimensions on the turret

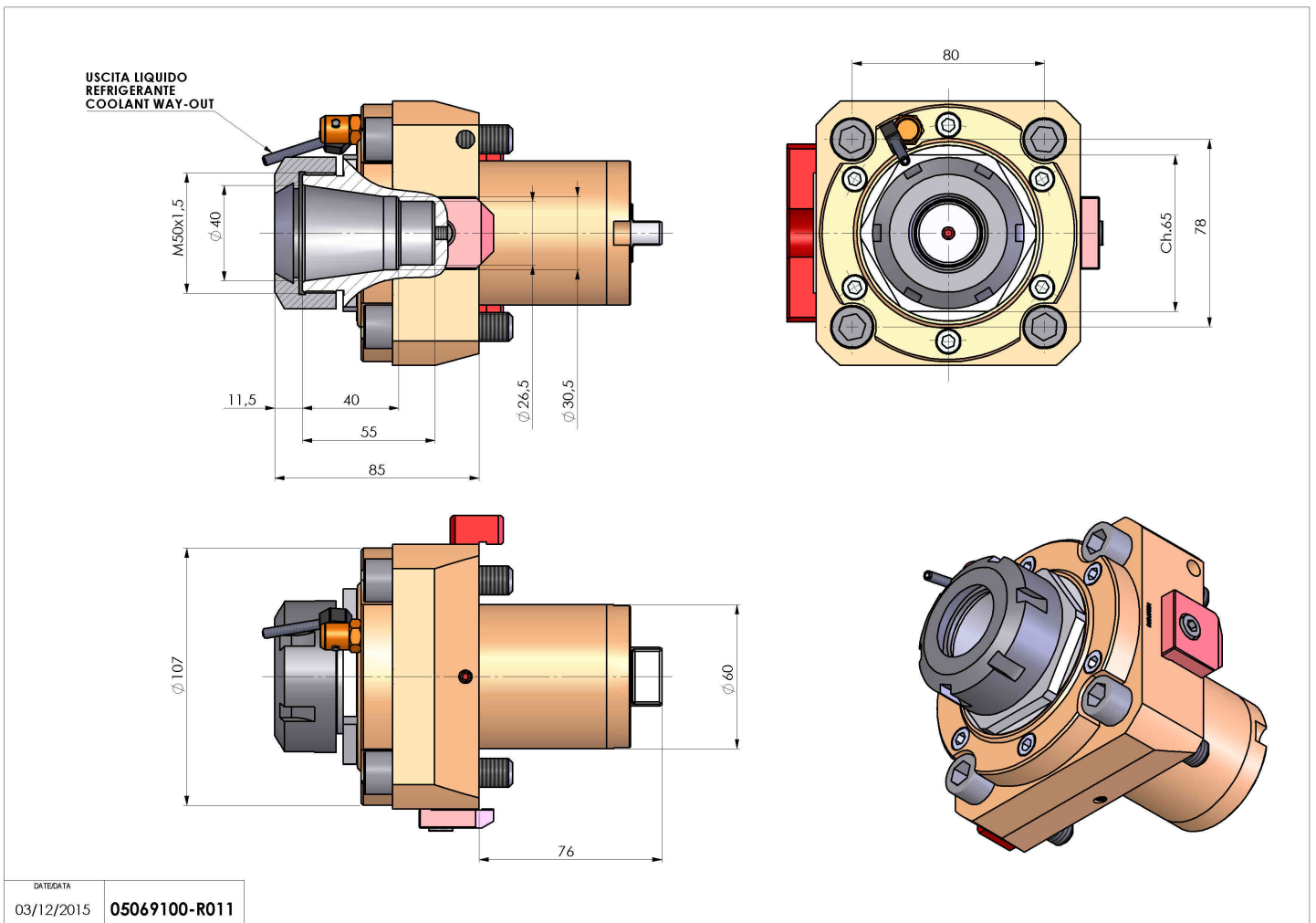

DATE/DATE	03/12/2015	05069100-R011
-----------	------------	---------------

Subject to technical changes