

05061500 - LT-A VDI40 ER32 R H110 OK

Type	LT-A Tool holder angle 90°
Mounting	VDI 40
Tool output	Collet nut ER 32
Coolant	External coolant
Direction of rotation	r1 ↻ r2 ↻
Max speed [rpm]	6000
Max torque [Nm]	63
Ratio	1:1
H [mm]	110
H1 [mm]	32,5
Accessories	N.A.
Notes	No more available. Soon out of stock
Mounting tips	Not suitable for every application, please check

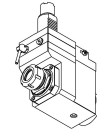

REPLACED BY 05266200

ATTENZIONE: VERIFICARE L'ORIENTAMENTO DELLA DENTATURA VDI

Always check live tool dimensions on the turret

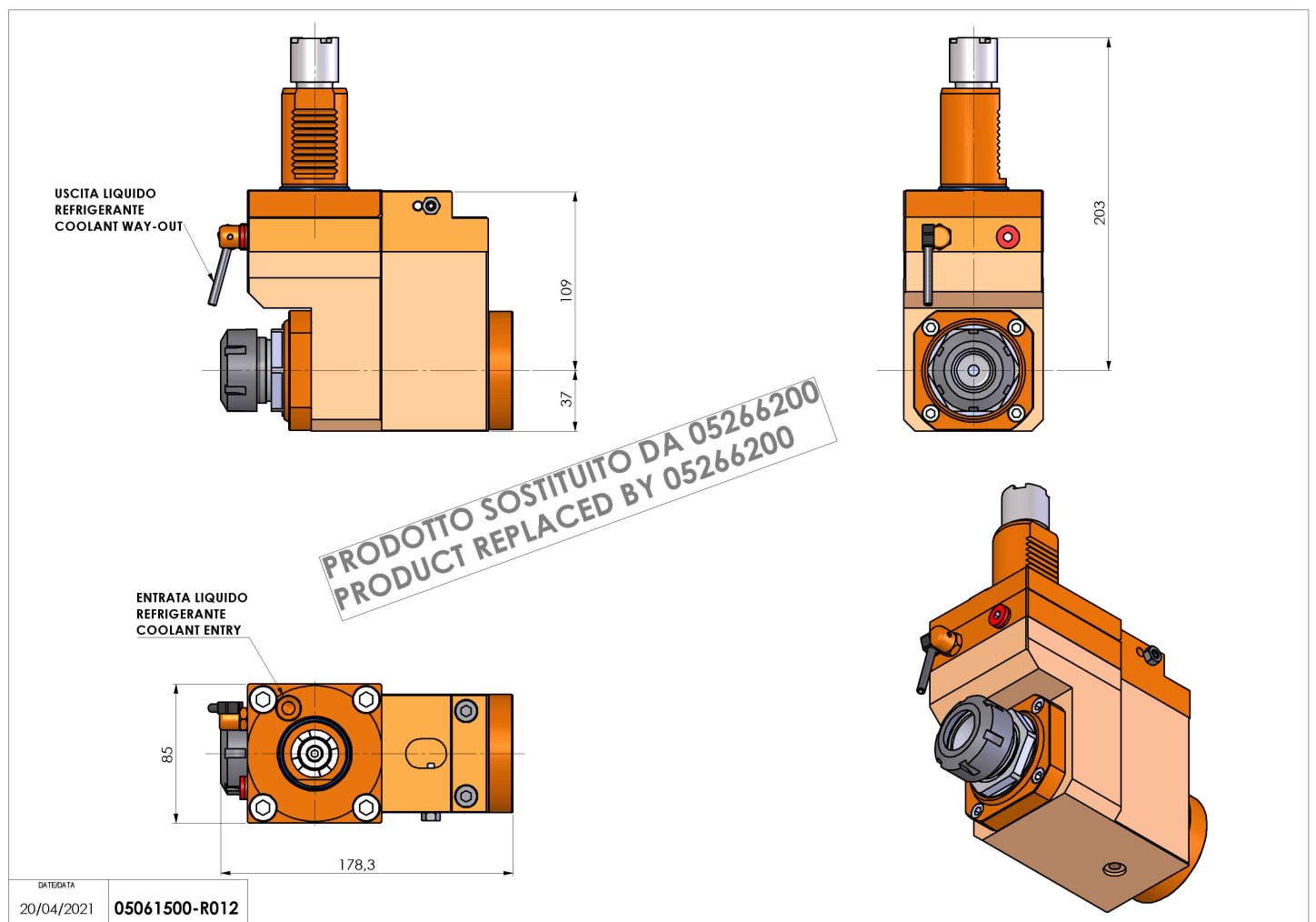

Subject to technical changes