

05060900 - LT-HOB-SAW D60 2,5:1 H70

| | |
|------------------------|--|
| Type | LT-HOB-SAW Hobbing/tool holder saw |
| Mounting | CYLINDRICAL SHANK 60 |
| Tool output | Shank kit Ø16-Ø22-Ø27 |
| Coolant | External coolant |
| Max speed [rpm] | 6000 |
| Max torque [Nm] | 32 |
| Ratio | 2,5:1 |
| H [mm] | 70 |
| Accessories | N.A. |
| Notes | N.A. |
| Mounting tips | Not suitable for every application, please check |

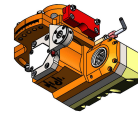

Always check live tool dimensions on the turret

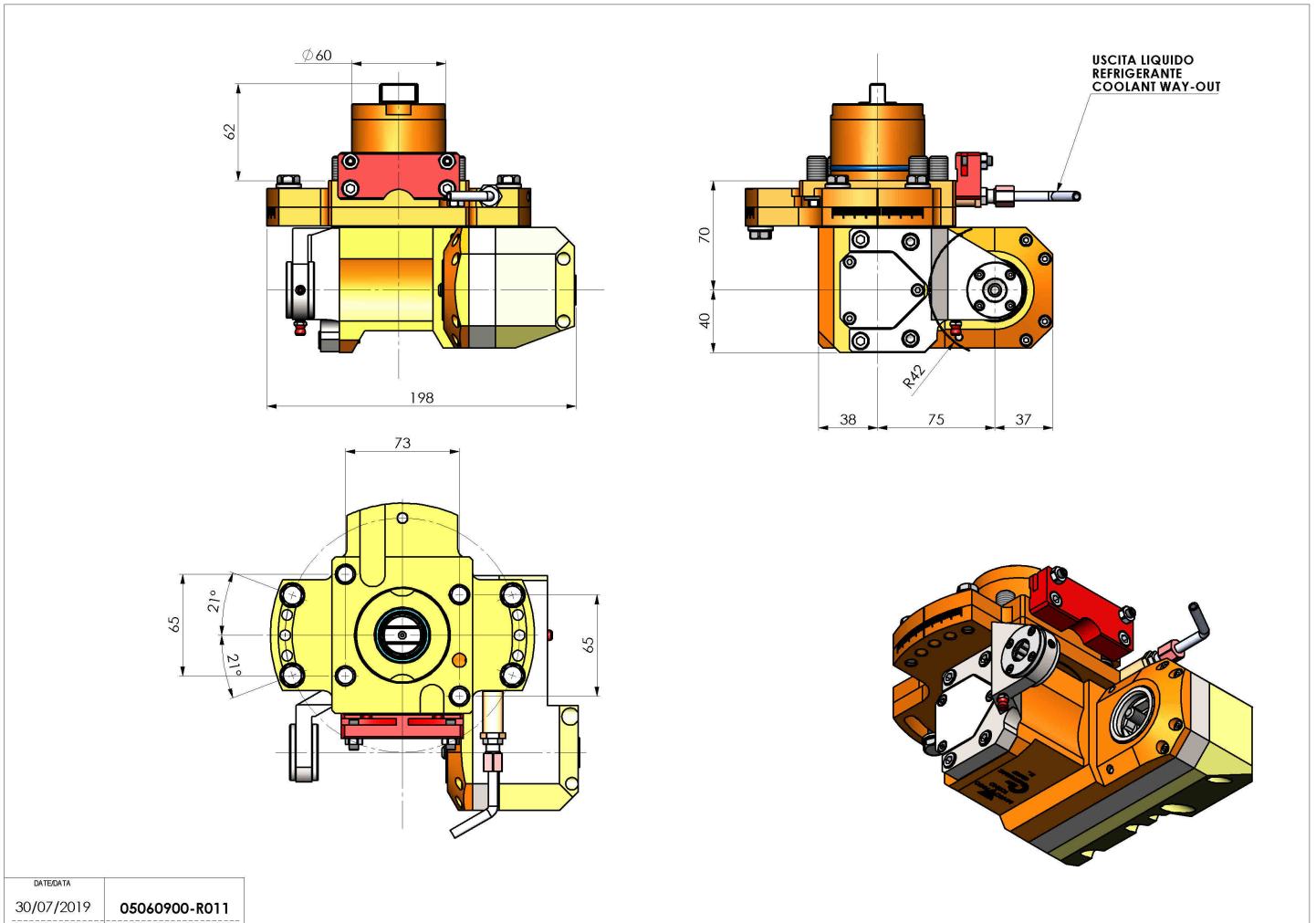

| | |
|------------|---------------|
| DATE/DATE | |
| 30/07/2019 | 05060900-R011 |

Subject to technical changes