

# 05027000 - LT-A D30 ER25F LR RF H75 TZ

<b>Type</b>	LT-A Tool holder angle 90°
<b>Mounting</b>	CYLINDRICAL SHANK 30
<b>Tool output</b>	Collet nut ER 25 F - internal nut
<b>Coolant</b>	Internal coolant
<b>Direction of rotation</b>	r1 ↻ r2 ↻
<b>Max speed [rpm]</b>	6000
<b>Max torque [Nm]</b>	30
<b>Ratio</b>	1:1
<b>H [mm]</b>	75
<b>H1 [mm]</b>	32,5
<b>Accessories</b>	N.A.
<b>Notes</b>	N.A.
<b>Mounting tips</b>	Not suitable for every application, please check

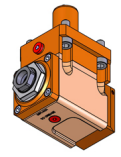

Always check live tool dimensions on the turret

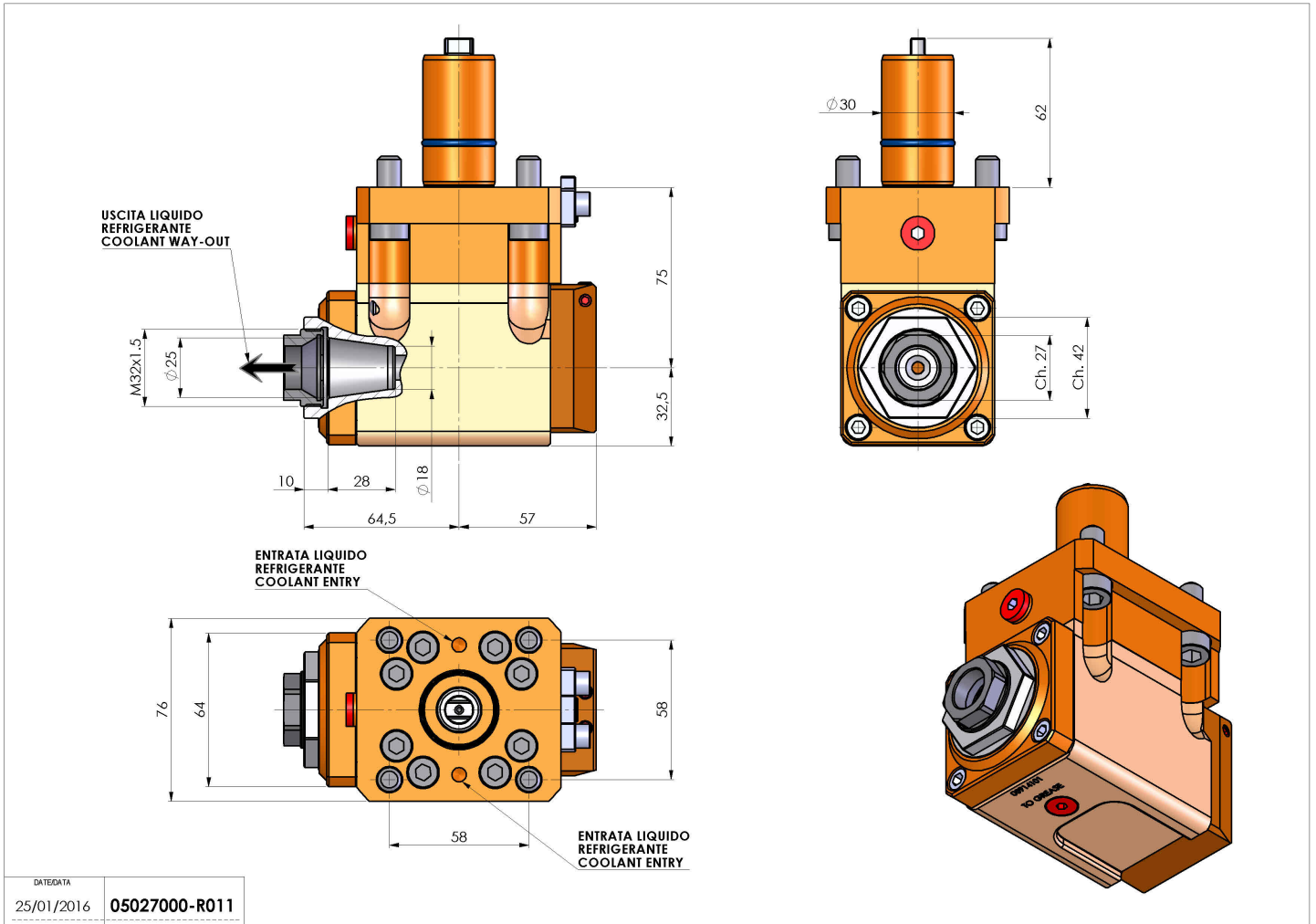

DATE/DATE: 25/01/2016  
**05027000-R011**

Subject to technical changes