

05020800 - LT-A VDI30 ER25 R H75 TAKAMAZ

| | |
|-----------------------|--|
| Type | LT-A OFS Tool holder offset angle 90° |
| Mounting | VDI 30 |
| Tool output | Collet nut ER 25 |
| Coolant | External coolant |
| Direction of rotation | r1 ↻ r2 ↻ |
| Max speed [rpm] | 6000 |
| Max torque [Nm] | 25 |
| Ratio | 1:1 |
| H [mm] | 75 |
| H1 [mm] | 29 |
| Accessories | N.A. |
| Notes | N.A. |
| Mounting tips | Not suitable for every application, please check |

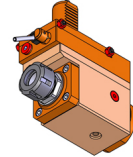

ATTENZIONE: VERIFICARE L'ORIENTAMENTO DELLA DENTATURA VDI

Always check live tool dimensions on the turret

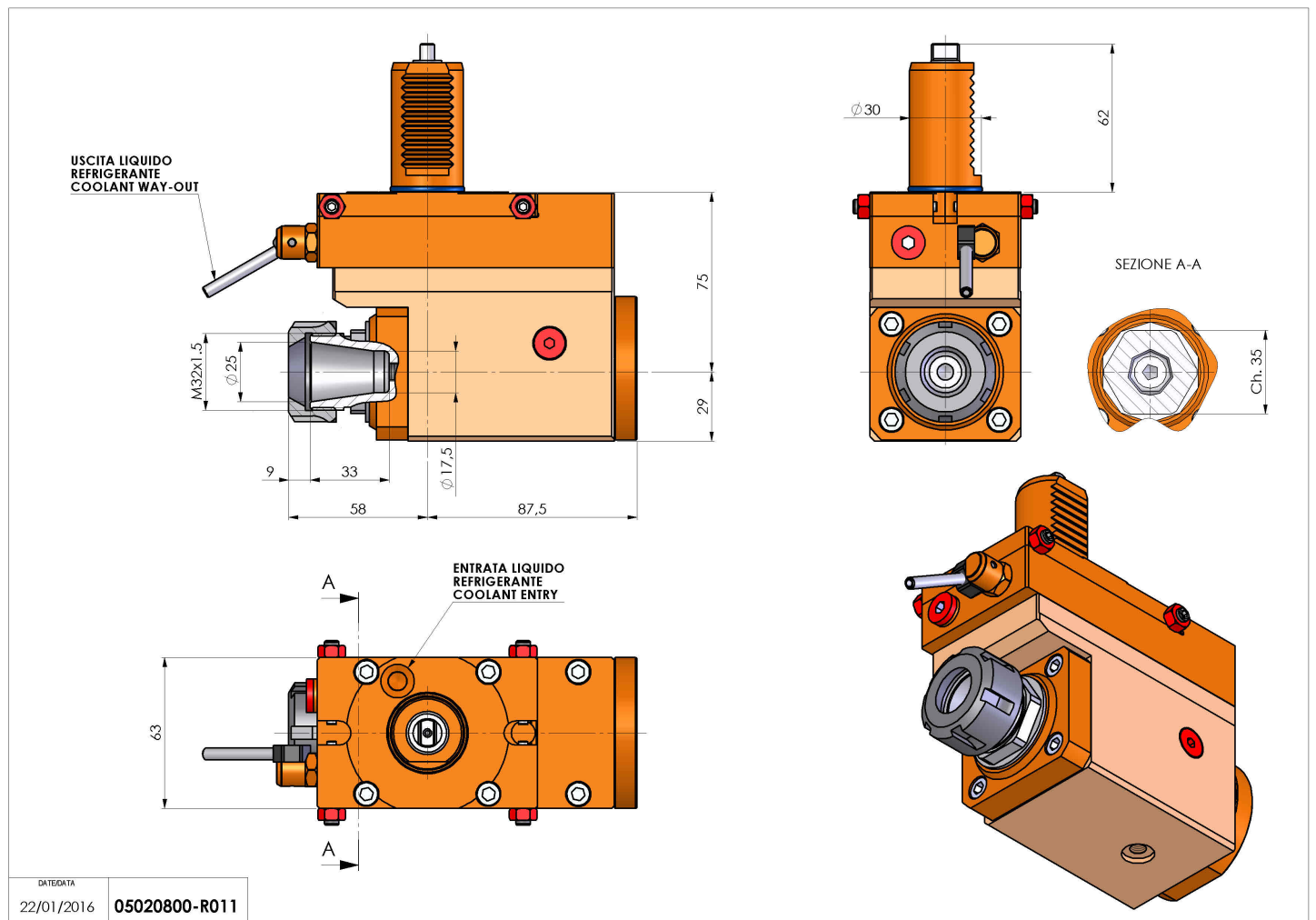

DATE/DATE
22/01/2016 05020800-R011

Subject to technical changes