

# 05450100 - LT-A D68 ER32F-32F HS H80

Type	LT-A DBL Tool holder double angle 90°
Mounting	CYLINDRICAL SHANK 68
Tool output	Collet nut ER 32 F - internal nut
Coolant	External coolant
Direction of rotation	r1 ↻ r2 ↻ r3 ↻
Max speed [rpm]	10000
Max torque [Nm]	63
Ratio	1:1
H [mm]	80
H1 [mm]	38
Accessories	N.A.
Notes	Replaced by cod. 05450400
Mounting tips	Not suitable for every application, please check

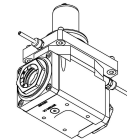

REPLACED BY 05450400

Always check live tool dimensions on the turret

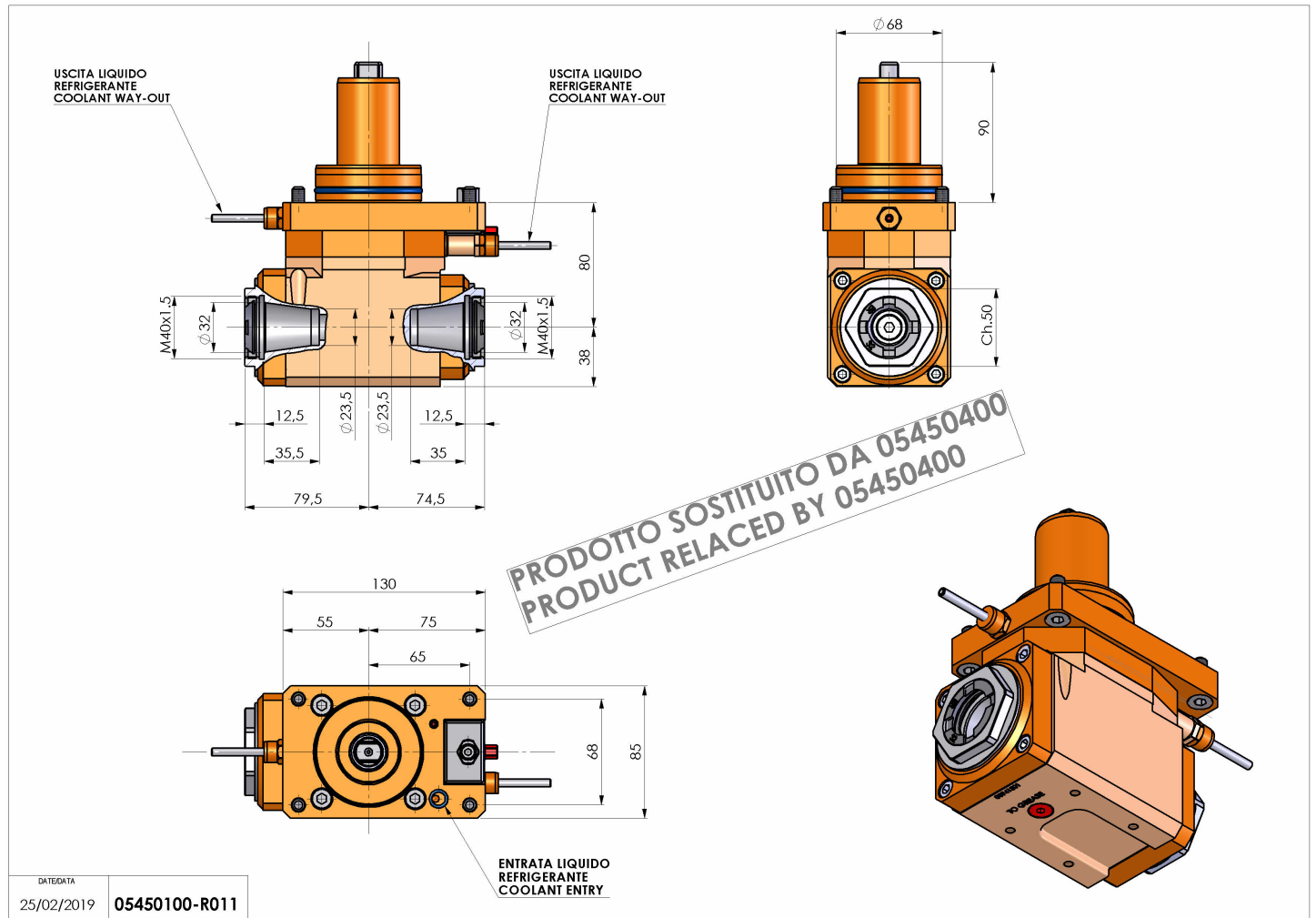

Subject to technical changes