

# 05400100 - LT-S D60 ER40 H102

|                              |  |
|------------------------------|--|
| <b>Type</b>                  | LT-S<br>Tool holder straight                     |
| <b>Mounting</b>              | CYLINDRICAL SHANK 60                             |
| <b>Tool output</b>           | Collet nut ER 40                                 |
| <b>Coolant</b>               | External coolant                                 |
| <b>Direction of rotation</b> | r1 ↻ r2 ↻  |
| <b>Max speed [rpm]</b>       | 6000   |
| <b>Max torque [Nm]</b>       | 70   |
| <b>Ratio</b>                 | 1:1  |
| <b>H [mm]</b>                | 102.5  |
| <b>Accessories</b>           | N.A.   |
| <b>Notes</b>                 | N.A.   |
| <b>Mounting tips</b>         | Not suitable for every application, please check |

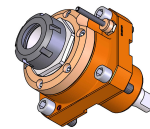

Always check live tool dimensions on the turret

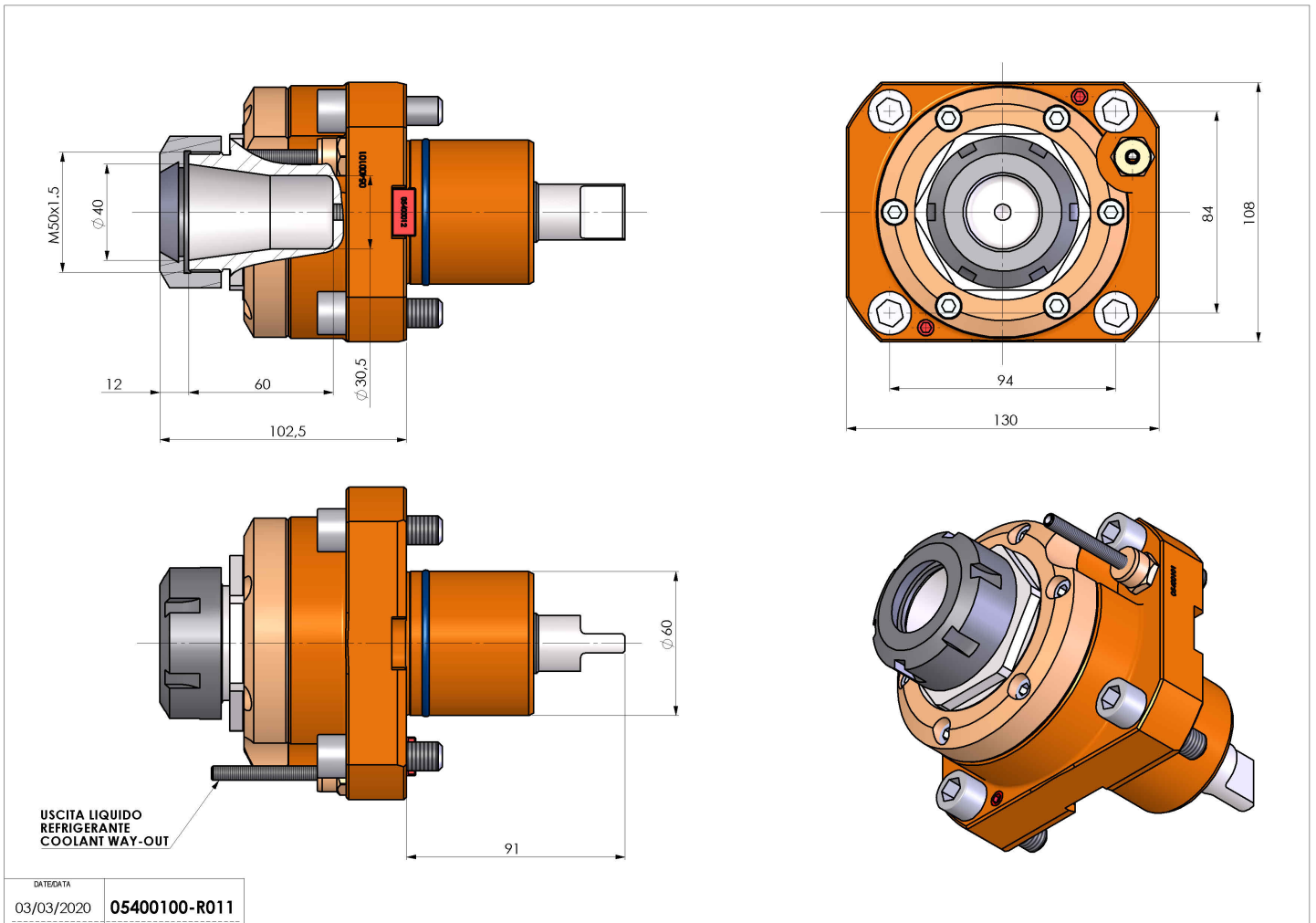

DATE/DATE: 03/03/2020 05400100-R011

Subject to technical changes