



05372000 - LT-S D55 C40 H56

Type	LT-S Tool holder straight
Mounting	CYLINDRICAL SHANK 55
Tool output	Polygonal shank C40 ISO 26623-1
Coolant	External coolant
Direction of rotation	r1  r2 
Max speed [rpm]	6000
Max torque [Nm]	63
Ratio	1:1
H [mm]	56
Accessories	N.A.
Notes	N.A.
Mounting tips	Not suitable for every application, please check



Always check live tool dimensions on the turret

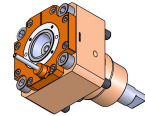
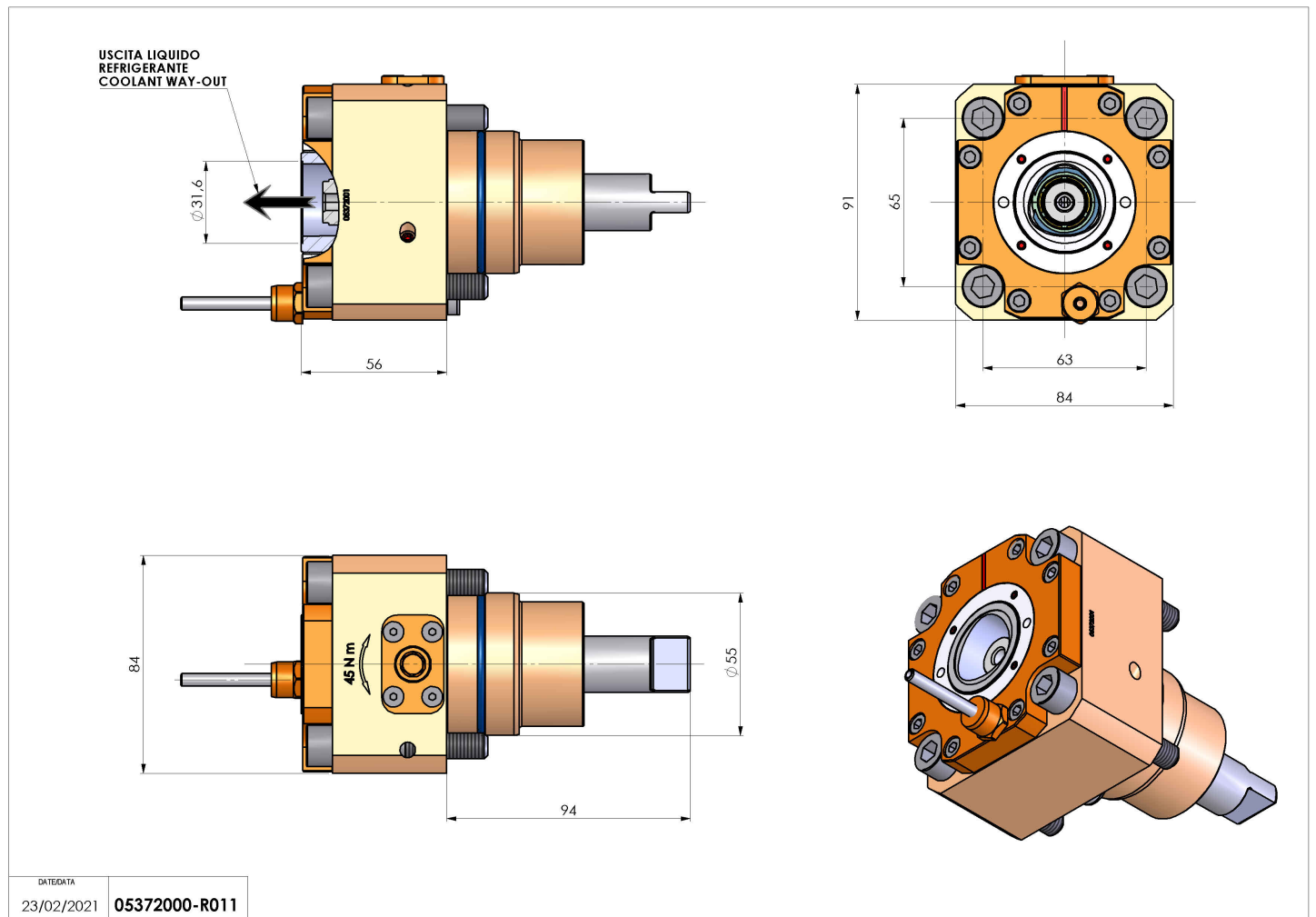

DATE/DATE
23/02/2021 05372000-R011

Subject to technical changes