

## 05364100 - LT-S D55.4 ER32F OFS63.5 LR HRF 2:1 H86.5

<b>Type</b>	LT-S OFS Tool holder straight offset
<b>Mounting</b>	CYLINDRICAL SHANK 55,4
<b>Tool output</b>	Collet nut ER 32 F - internal nut
<b>Coolant</b>	HP Internal coolant
<b>Offset [mm]</b>	63.5
<b>Direction of rotation</b>	r1  r2
<b>Max speed [rpm]</b>	in 6000 / out 3000
<b>Max torque [Nm]</b>	in 25 / out 50
<b>Ratio</b>	2:1
<b>H [mm]</b>	86.5
<b>Accessories</b>	N.A.
<b>Notes</b>	N.A.
<b>Mounting tips</b>	Not suitable for every application, please check

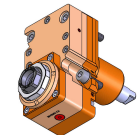

Always check live tool dimensions on the turret

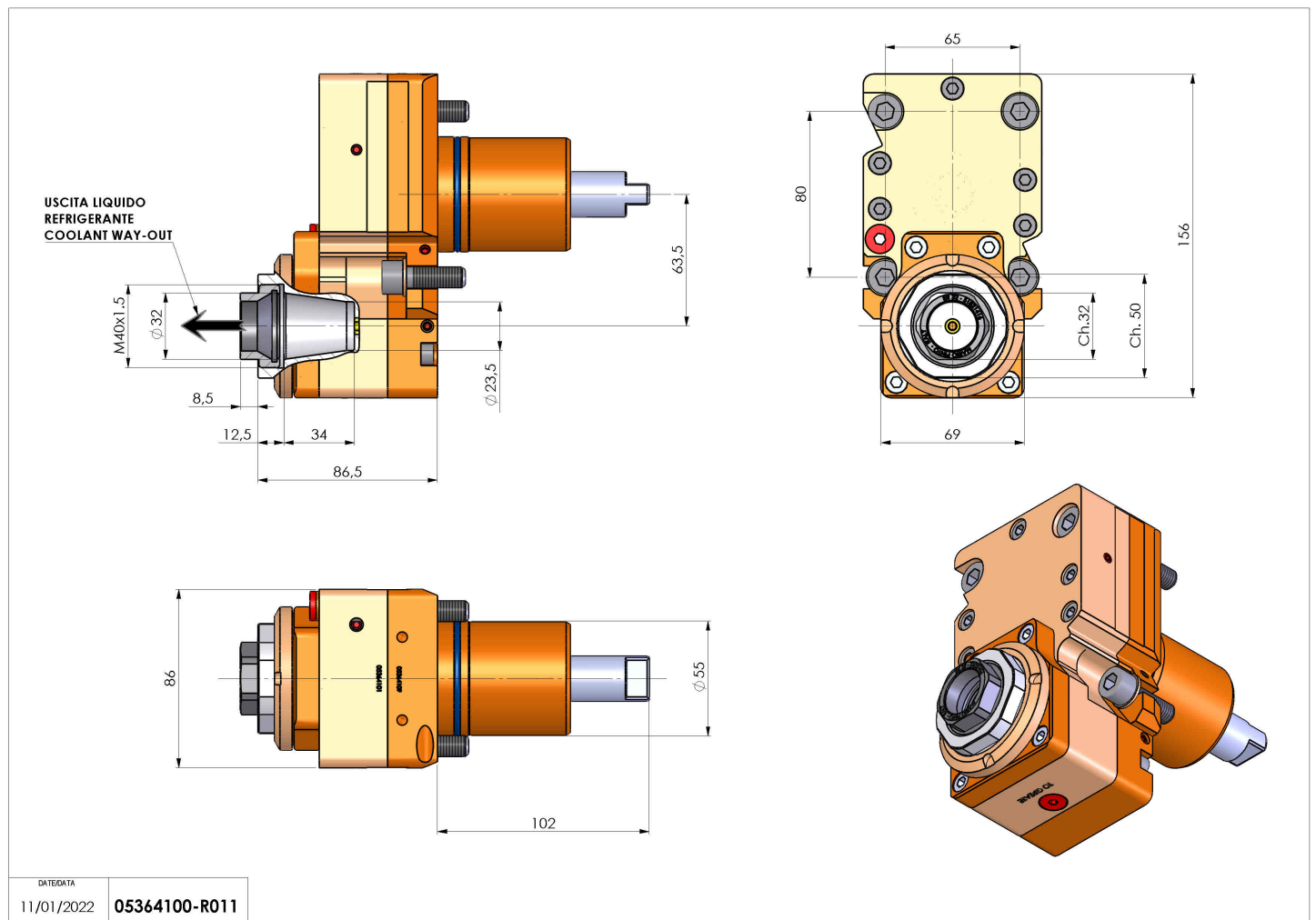

DATE/DATE	
11/01/2022	<b>05364100-R011</b>

**Subject to technical changes**