

# 05357600 - LT-A ST65 VDI40 C16 H135

<b>Type</b>	LT-A ST Slotting tool 90°
<b>Mounting</b>	VDI 40
<b>Tool output</b>	Tool diameter 16
<b>Coolant</b>	External coolant
<b>Max speed [rpm]</b>	700
<b>Max torque [Nm]</b>	17.5
<b>Ratio</b>	1:1
<b>Y axis adjustment</b>	NO
<b>Feed pushing [N]</b>	1000
<b>Stroke [mm]</b>	65
<b>Work stroke [mm]</b>	60
<b>H [mm]</b>	135
<b>Accessories</b>	N.A.
<b>Notes</b>	N.A.
<b>Mounting tips</b>	Not suitable for every application, please check

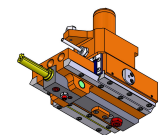

**ATTENZIONE: VERIFICARE L'ORIENTAMENTO DELLA DENTATURA VDI**

Always check live tool dimensions on the turret

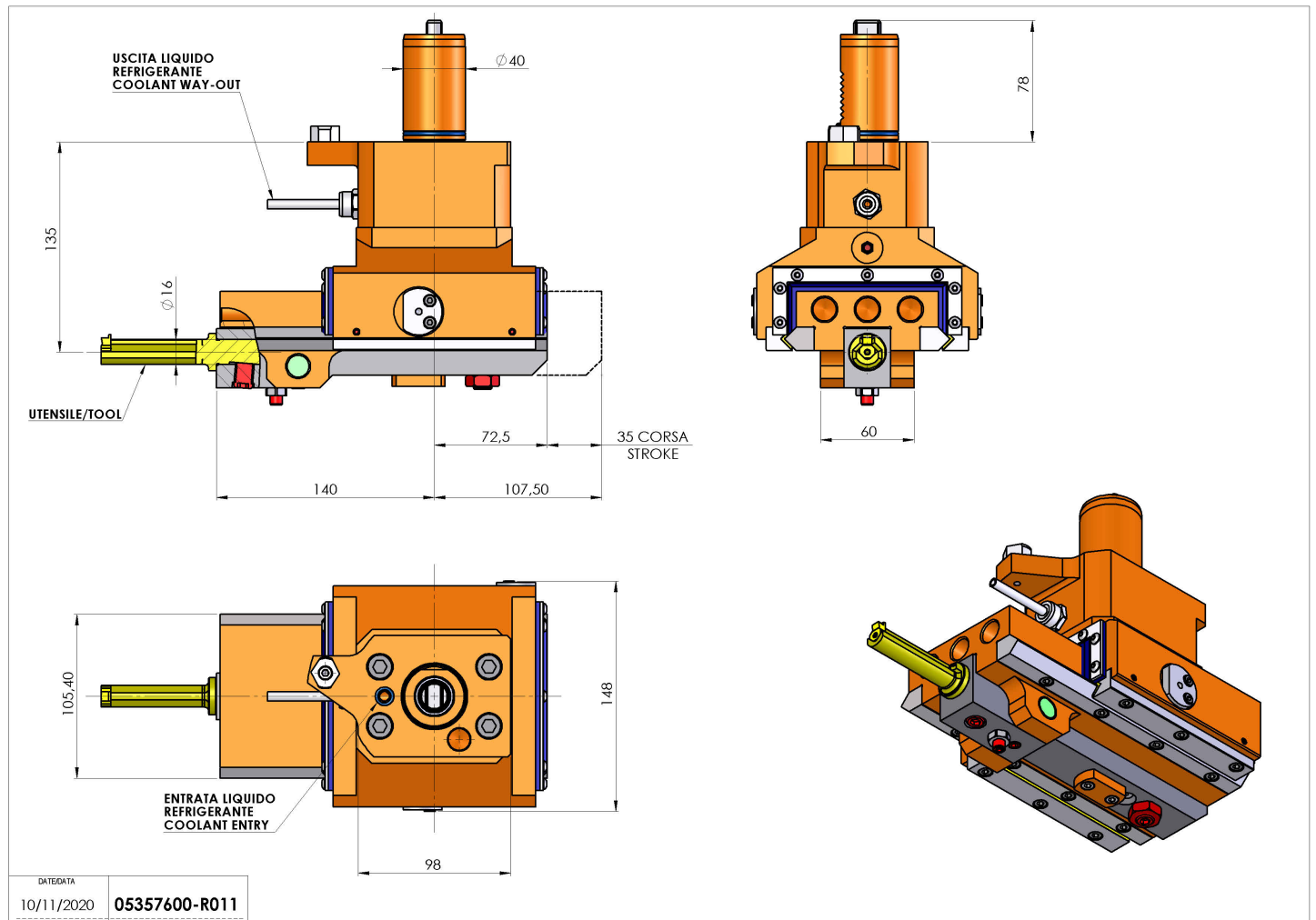

DATE/GATE  
10/11/2020 **05357600-R011**

Subject to technical changes