

05334200 - LT-A BMT55 DIN138-22 LR 2:1 H85

Type	LT-A Tool holder angle 90°
Mounting	BMT 55
Tool output	Shell-Mill DIN138 22
Coolant	External coolant
Direction of rotation	r1 ↻ r2 ↻
Max speed [rpm]	in 6000 / out 3000
Max torque [Nm]	in 70 / out 140
Ratio	2:1
H [mm]	85
H1 [mm]	38
Accessories	N.A.
Notes	N.A.
Mounting tips	Not suitable for every application, please check

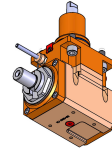

Always check live tool dimensions on the turret

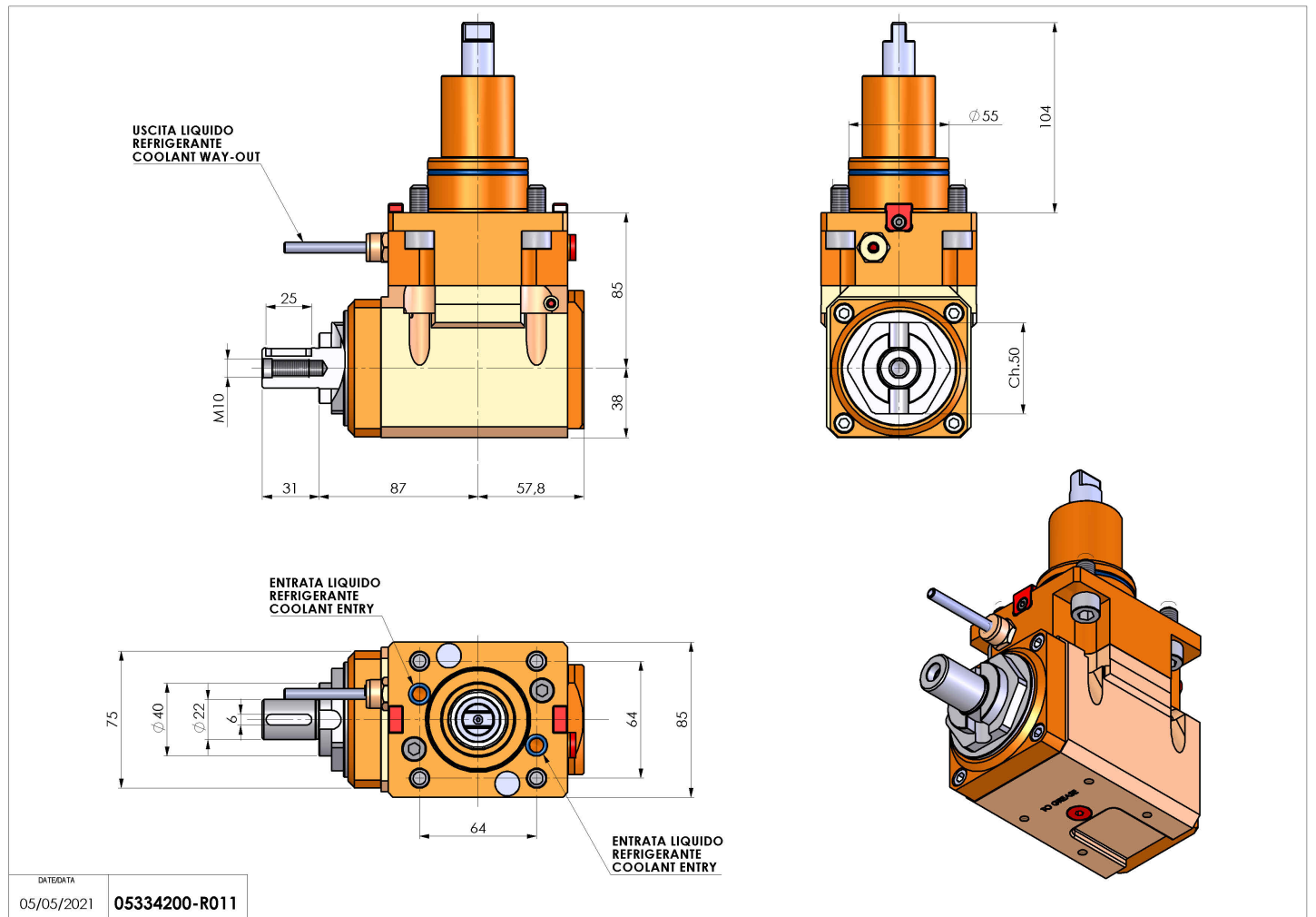

Subject to technical changes