

# 05306600 - LT-S-A BMT85 ER32F-32F H132-85

<b>Type</b>	LT-S-A Tool holder double vertical horizontal
<b>Mounting</b>	BMT 85
<b>Tool output</b>	Collet nut ER 32 F - internal nut
<b>Coolant</b>	External coolant
<b>Direction of rotation</b>	r1 ↻ r2 ↻ r3 ↻
<b>Max speed [rpm]</b>	4000
<b>Max torque [Nm]</b>	50
<b>Ratio</b>	1:1
<b>H [mm]</b>	133-85
<b>Accessories</b>	N.A.
<b>Notes</b>	
<b>Mounting tips</b>	Not suitable for every application, please check

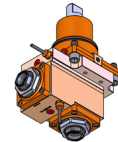

Always check live tool dimensions on the turret

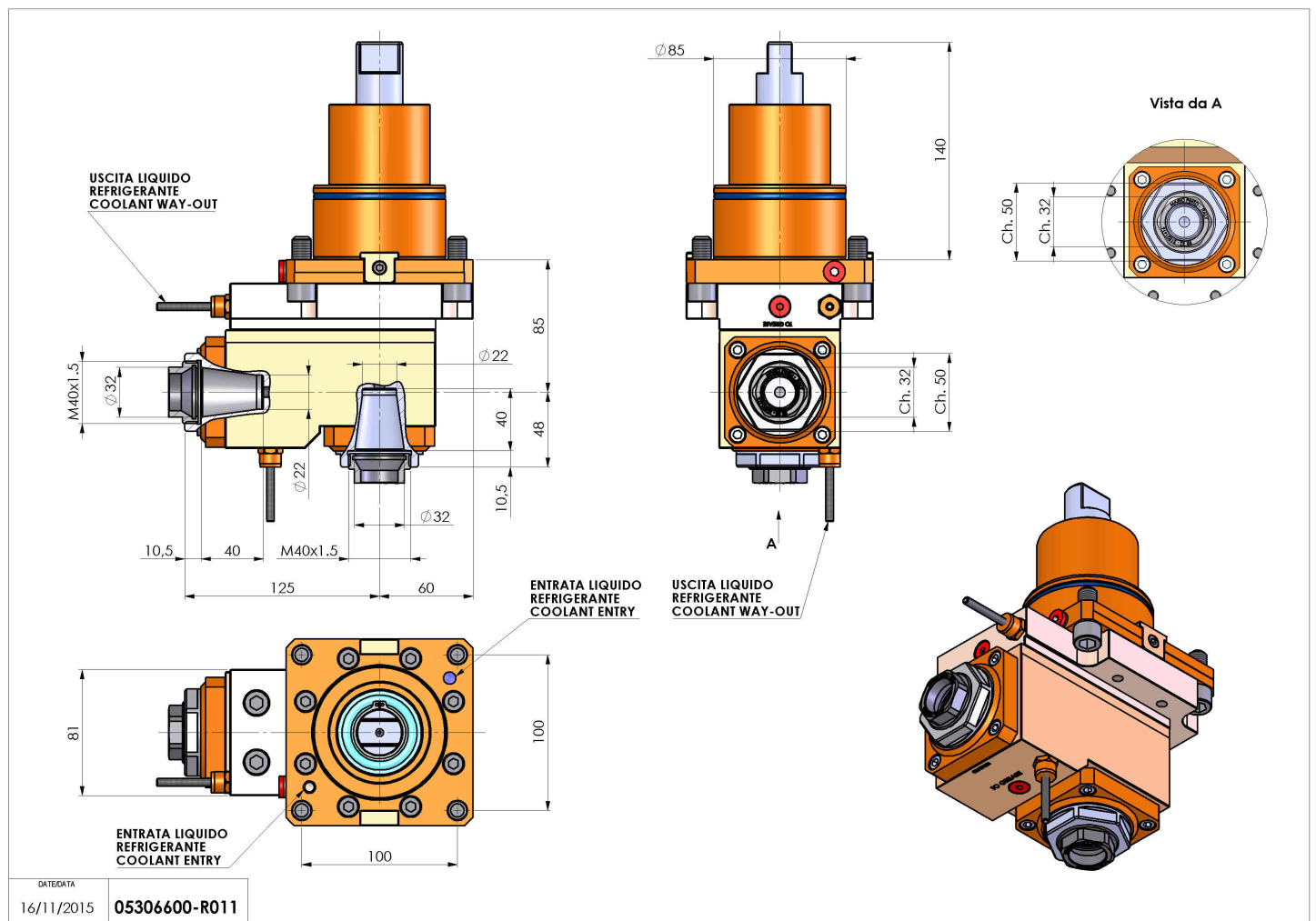

Subject to technical changes