



05301500 - LT-A BMT55 ER25 1:2 KR H70

Type	LT-A Tool holder angle 90°
Mounting	BMT 55
Tool output	Collet nut ER 25
Coolant	With coolant kit
Direction of rotation	r1  r2 
Max speed [rpm]	in 6000 / out 12000
Max torque [Nm]	in 60 / out 30
Ratio	1:2
H [mm]	70
H1 [mm]	32,5
Accessories	N.A.
Notes	N.A.
Mounting tips	Not suitable for every application, please check



Always check live tool dimensions on the turret

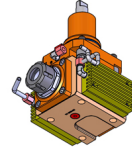
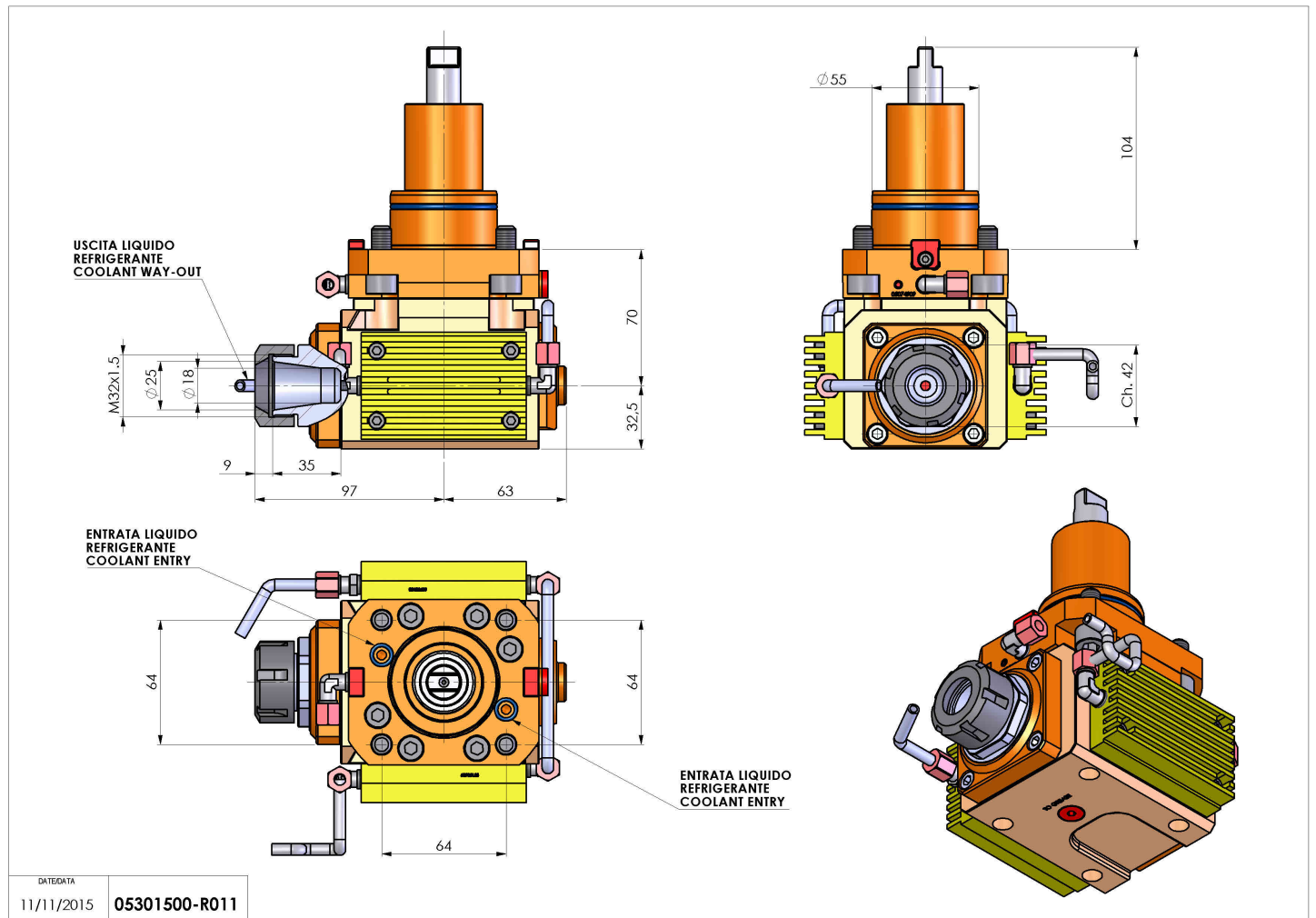

DATE/DATE
11/11/2015 05301500-R011

Subject to technical changes