

# 05280900 - LT-A D54 ER25 HRF H75

<b>Type</b>	LT-A Tool holder angle 90°
<b>Mounting</b>	CYLINDRICAL SHANK 54
<b>Tool output</b>	Collet nut ER 25
<b>Coolant</b>	HP Internal coolant
<b>Direction of rotation</b>	r1  r2
<b>Max speed [rpm]</b>	6000
<b>Max torque [Nm]</b>	40
<b>Ratio</b>	1:1
<b>H [mm]</b>	75
<b>H1 [mm]</b>	32,5
<b>Max pressure [bar]</b>	80
<b>Accessories</b>	N.A.
<b>Notes</b>	N.A.
<b>Mounting tips</b>	Not suitable for every application, please check

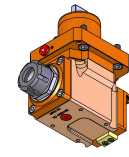

Always check live tool dimensions on the turret

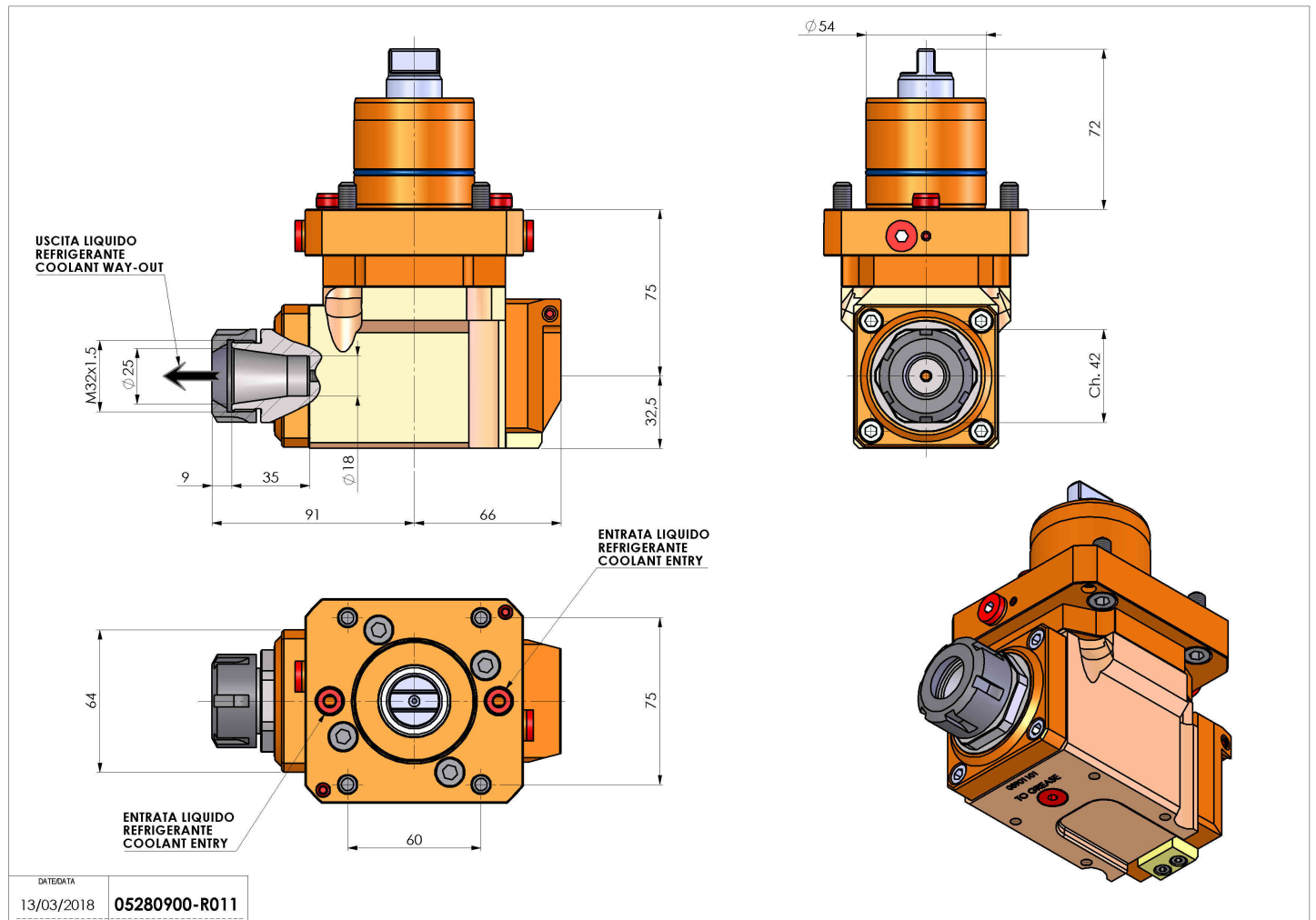

DATE/ATA	13/03/2018
PART NUMBER	05280900-R011

Subject to technical changes