

05261000 - LT-A ST65 D60 C16H105 CR-AY OK

Type	LT-A ST Slotting tool 90°
Mounting	CYLINDRICAL SHANK 60
Tool output	Tool diameter 16
Coolant	External coolant
Max speed [rpm]	500
Y axis adjustment	SI
Feed pushing [N]	30
Stroke [mm]	65
Work stroke [mm]	60
Y axis adjust. [mm]	±0,4
H [mm]	105
Accessories	N.A.
Notes	N.A.
Mounting tips	Not suitable for every application, please check

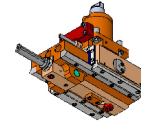

Always check live tool dimensions on the turret

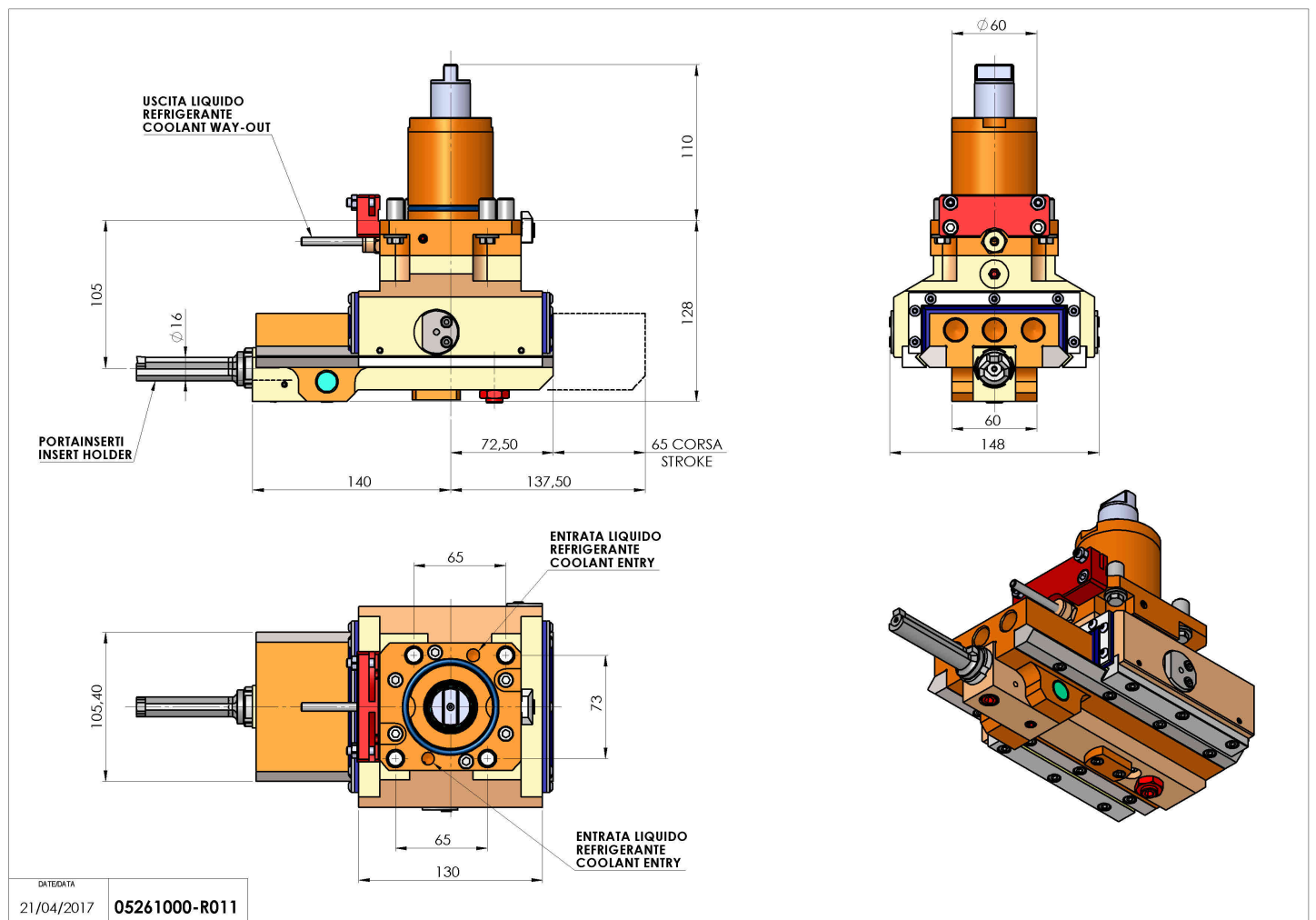

DATE/DATE
21/04/2017 **05261000-R011**

Subject to technical changes