

# 05257800 - LT-A VDI50 ER40F-40F L H160 MZ

Type	LT-A DBL Tool holder double angle 90°
Mounting	VDI 50
Tool output	Collet nut ER 40 F - internal nut
Coolant	External coolant
Direction of rotation	r1 ↻ r2 ↻ r3 ↻
Max speed [rpm]	6000
Max torque [Nm]	80
Ratio	1:1
H [mm]	160
H1 [mm]	43
Accessories	N.A.
Notes	N.A.
Mounting tips	Not suitable for every application, please check

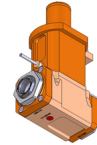

**ATTENZIONE: VERIFICARE L'ORIENTAMENTO DELLA DENTATURA VDI**

Always check live tool dimensions on the turret

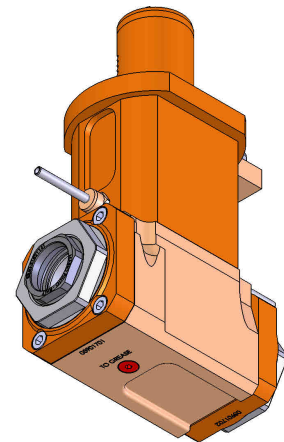
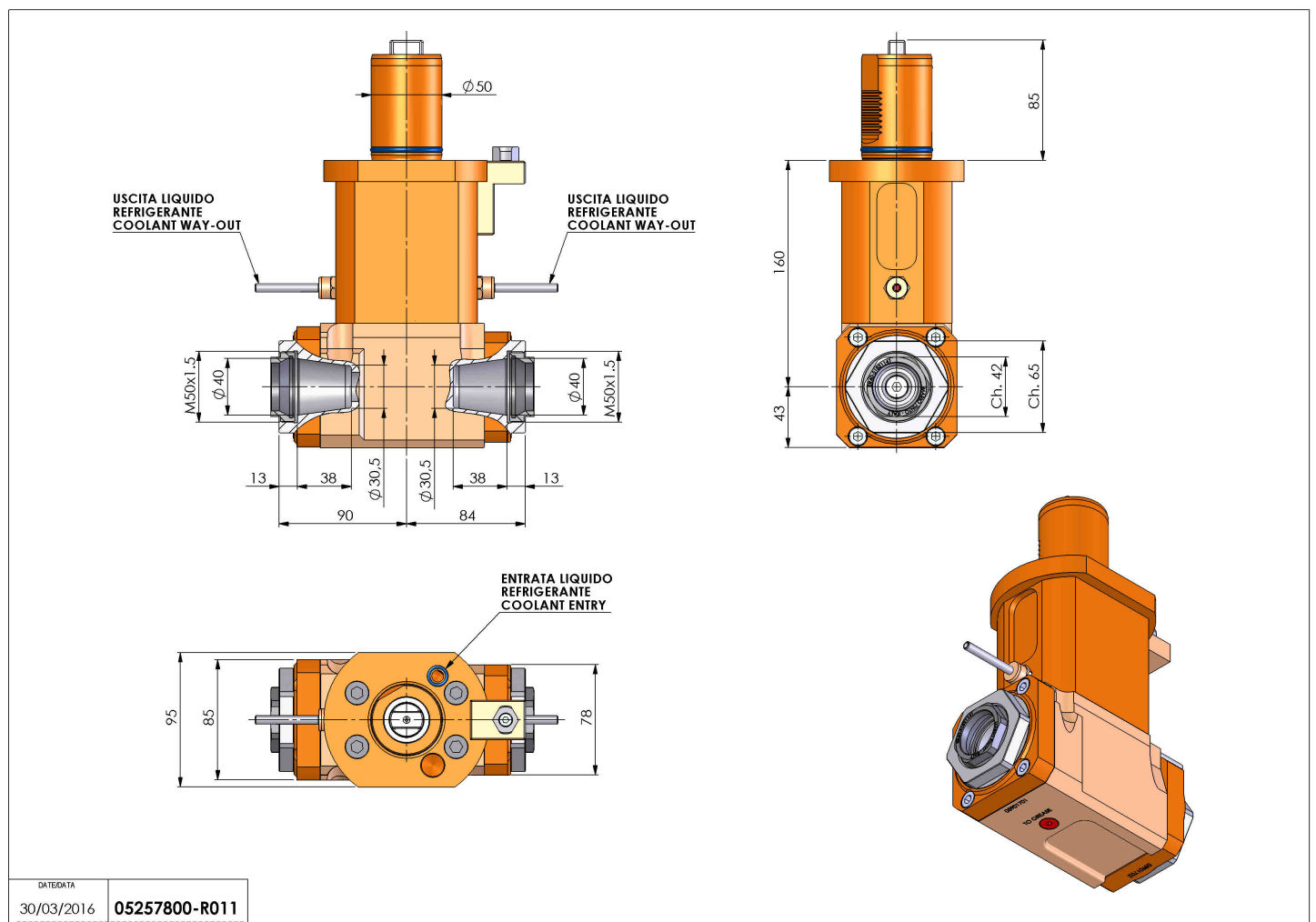

DATE/GATE  
30/03/2016 05257800-R011

Subject to technical changes