



05253800 - LT-A VDI40 ER32 L HRF H100MZ

Type	LT-A Tool holder angle 90°
Mounting	VDI 40
Tool output	Collet nut ER 32
Coolant	HP Internal coolant
Direction of rotation	r1  r2 
Max speed [rpm]	6000
Max torque [Nm]	63
Ratio	1:1
H [mm]	100
H1 [mm]	37
Max pressure [bar]	80
Accessories	N.A.
Notes	N.A.
Mounting tips	Not suitable for every application, please check

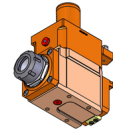

ATTENZIONE: VERIFICARE L'ORIENTAMENTO DELLA DENTATURA VDI

Always check live tool dimensions on the turret

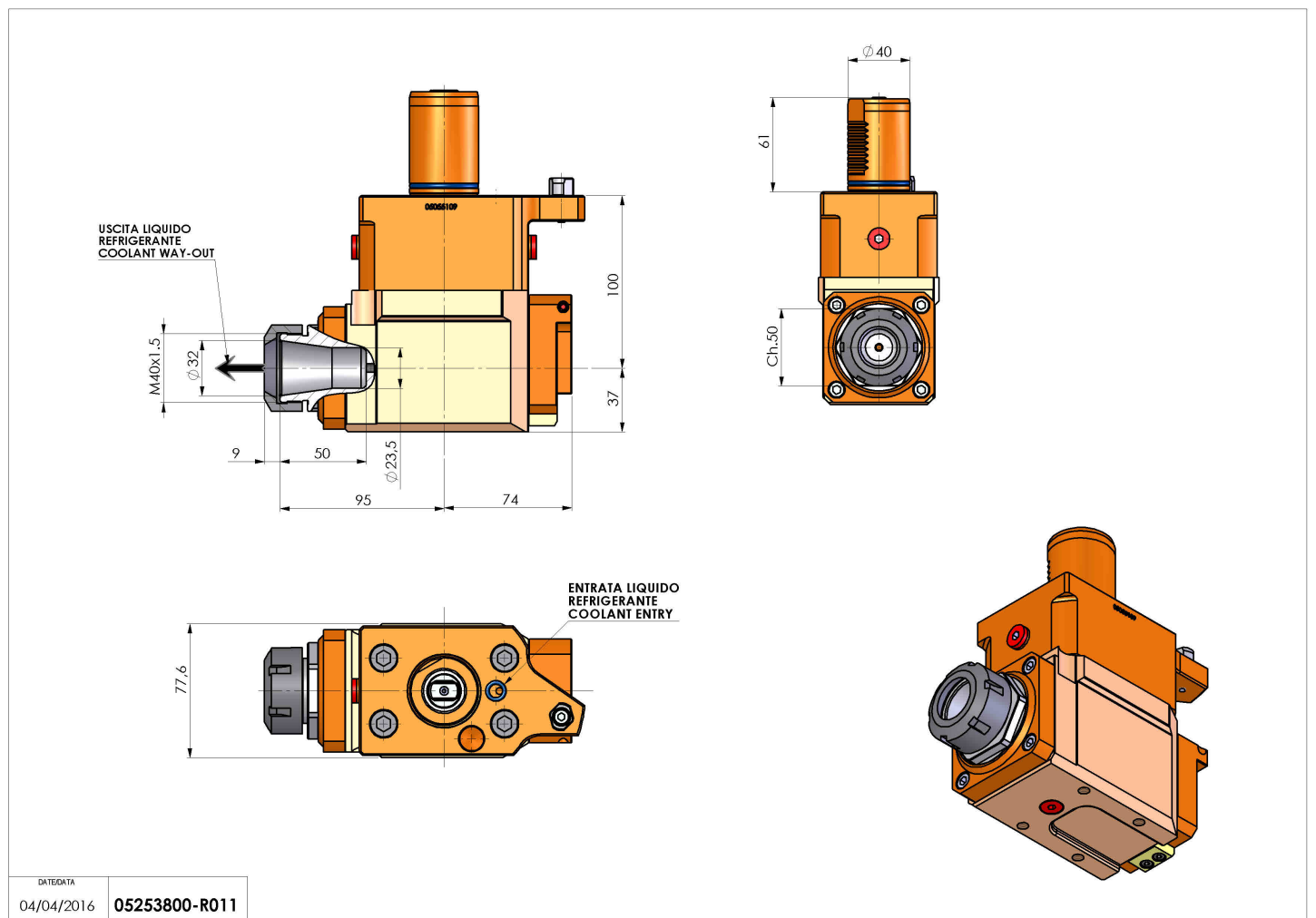

DATE/DATE	04/04/2016
05253800-R011	

Subject to technical changes